

HDMI Switcher

IMP-S Series

IMP-S21U/IMP-S41U

<User Guide>

Ver.2.1.0

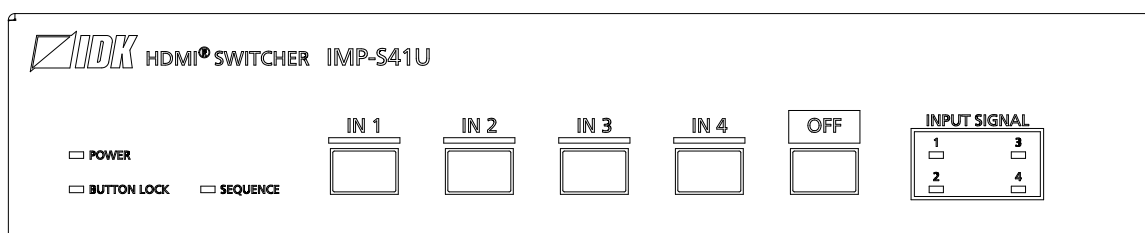
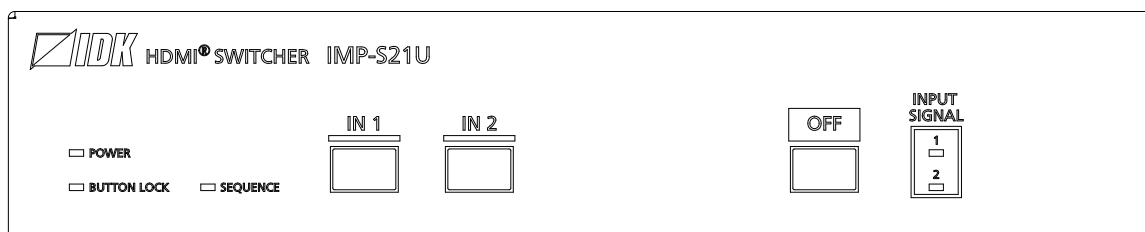

- Thank you for choosing our product.
- To ensure the best performance of this product, please read this user guide fully and carefully before using it and keep this manual together with the product for future reference as needed.

IDK Corporation

Trademarks

- Blu-ray Disc and Blu-ray are trademarks of Blu-ray Disc Association.
- The terms HDMI and HDMI High-Definition Multimedia Interface, and the HDMI Logo are trademarks or registered trademarks of HDMI Licensing Administrator, Inc. in the United States and other countries.
- Javascript® is a trademark or registered trademark of Oracle Corporation, its subsidiaries, and affiliated companies in the United States and other countries.
- Oracle and Java are trademarks of Oracle Corporation its subsidiaries, and affiliated companies in the United States and other countries.
- The terms Anti-snow and Connection Reset are registered trademarks of IDK Corporation in Japan.
- All other company and product names mentioned in this manual are either registered trademarks or trademarks of their respective owners. In this manual, the “®” or “™” marks may not be specified.

Before reading this manual

- All rights reserved.
- Some information contained in this User guide such as exact product appearance, diagrams, menu operations, and so on may differ depending on the product version.
- This User guide is subject to change without notice. You can download the latest version from IDK's website at: www.idkav.com

The reference manual consists of the following two volumes:

- User guide (this document):
Provides explanations and procedures for operations, installation, connections among devices, I/O adjustment and settings.
- Command guide: Please download the command guide from the website above.
Provides explanations and procedures for external control using RS-232C and LAN communications.

FCC STATEMENT

This equipment has been tested and found to comply with the limits for a Class A digital device, pursuant to part 15 of the FCC Rules. These limits are designed to provide reasonable protection against harmful interference when the equipment is operated in a commercial environment. This equipment generates, uses, and can radiate radio frequency energy and, if not installed and used in accordance with the instruction manual, may cause harmful interference to radio communications. Operation of this equipment in a residential area is likely to cause harmful interference, in which case the user will be required to correct the interference at his own expense.

CE MARKING

This equipment complies with the essential requirements of the relevant European health, safety and environmental protection legislation.

WEEE MARKING











Waste Electrical and Electronic Equipment (WEEE), Directive 2002/96/EC
(This directive is only valid in the EU.)

This equipment complies with the WEEE Directive (2002/96/EC) marking requirement.
The left marking indicates that you must not discard this electrical/electronic equipment in domestic household waste.

Safety Instructions

Read and understand all safety and operating instructions before using this product. Follow all instructions and heed all warnings/cautions.

Enforcement Symbol	Description
 Warning	Indicates the presence of a hazard that may result in death or serious personal injury if the warning is ignored or the product is handled incorrectly.
 Caution	Indicates the presence of a hazard that may cause minor personal injury or property damage if the caution is ignored or the product is handled incorrectly.



Symbol	Description	Example
 Caution	This symbol is intended to alert the user. (Warning and caution)	 Hot surfaces Caution
 Prohibited	This symbol is intended to prohibit the user from specified actions.	 Do not disassemble
 Instruction	This symbol is intended to instruct the user.	 Unplug

Warning





■ For lifting heavy products:

 Instruction	<ul style="list-style-type: none"> ● Lifting must be done by two or more personnel. <p>To avoid injury: When lifting the product, bend your knees, keep your back straight and get close to it with two or more persons.</p>
---	--

■ For installing and connecting products:

 Prohibited	<ul style="list-style-type: none"> ● Do not place the product upon a surface that may give way or that may become unstable. <p>Install the product in a secure and stable place to prevent it from falling and possibly causing injury.</p> <ul style="list-style-type: none"> ● Secure the product if installing in locations prone to vibration or movement. <p>Otherwise, it may move unexpectedly or it may fall and lead to injury.</p>
 Instruction	<ul style="list-style-type: none"> ● Installation work must be performed by professionals. <p>The product is intended to be installed by skilled technicians. For installation, please contact a system integrator or IDK. Improper installation may lead to the risk of fire, electric shock, injury, or property damage.</p> <ul style="list-style-type: none"> ● Insert the power plug into an outlet that is unobstructed. <p>Unobstructed access to the plug enables unplugging the product in case of any extraordinary failure, abnormal situation or for easy disconnection during extended periods of non-use.</p> <ul style="list-style-type: none"> ● Insert the power plug into an appropriate outlet completely. <p>If the plug is partially inserted, arcing may cause the connection to overheat, increasing the risk of electrical shock or fire. Do not use a damaged plug or connect to a damaged outlet.</p> <ul style="list-style-type: none"> ● Unplug the product from the AC power source during installation or service. <p>When connecting peripheral devices to this product, unplug all involved devices from outlets. Ground potential differences may cause fire or other difficulties.</p>

■ For operating products:

 Prohibited	<ul style="list-style-type: none"> ● Keep out any foreign objects. <p>To avoid fire or electric shock, do not permit foreign objects, such as metal and paper, to enter the product from vent holes or other apertures.</p> <ul style="list-style-type: none"> ● For power cable/plug: <ul style="list-style-type: none"> ▪ Do not scratch, heat, or modify, including splicing or lengthening them. ▪ Do not pull, place heavy objects on them, or pinch them. ▪ Do not bend, twist, tie or clamp them together forcefully. <p>Misuse of the power cable and plug may cause fire or electric shock. If power cables/plugs become damaged, contact your IDK representative.</p>
 Do not disassemble	<ul style="list-style-type: none"> ● Do not repair, modify or disassemble. <p>Since the product includes circuitry that uses potentially lethal, high voltage levels, disassembly by unauthorized personnel may lead to the risk of fire or electric shock. For internal inspection or repair, contact your IDK representative.</p>
 Do not touch	<ul style="list-style-type: none"> ● Do not touch the product and connected cables during electrical storms. <p>Contact may cause electric shock.</p>
 Instruction	<ul style="list-style-type: none"> ● Clean the power plug regularly. <p>If the plug is covered in dust, it may increase the risk of fire.</p> <ul style="list-style-type: none"> ● The product must be earthed. <p>To reduce the risk of electrical shock, ensure the product is connected to a mains socket outlet with a protective earthing connection.</p>



■ **If the following problem occurs:**

 Unplug	<ul style="list-style-type: none"> ● Unplug immediately if the product smokes, makes unusual noise, or produces a burning odor. If you continue to use the product under these conditions, it may cause electric shock or fire. ● Unplug immediately if the product is damaged by falling or having been dropped. If you continue to use the product under these conditions, it may increase the risk of electrical shock or fire. For maintenance and repair, contact your IDK representative. ● Unplug immediately if water or other objects are directed inside. If you continue to use the product under these conditions, it may increase the risk of electrical shock or fire. For maintenance and repair, contact your IDK representative.
--	---



Caution

■ **For installing and connecting products:**

 Prohibited	<ul style="list-style-type: none"> ● Do not place the product in a location where it will be subjected to high temperatures. If the product is subjected to direct sunlight or high temperatures while under operation, it may affect the product's performance and reliability and may increase the risk of fire. ● Do not store or operate the product in dusty, oil smoke filled, or humid place. If the product is placed near humidifiers or in a dusty area, it may increase the risk of fire or electric shock. ● Do not block the vent holes. If ventilation slots are blocked, it may cause the product to overheat, affecting performance and reliability and may increase the risk of fire. ● Do not place or stack heavy items on the product. Failure to observe this precaution may result in damage to the product and other property and may lead to the risk of personal injury. ● Do not exceed ratings of outlet and wiring devices. Exceeding the rating of an outlet may increase the risk of fire and electric shock.
 No wet hands	<ul style="list-style-type: none"> ● Do not handle power plug with wet hands. Failure to observe this precaution may increase the risk of electrical shock.
 Instruction	<ul style="list-style-type: none"> ● Use and store the product within the specified temperature/humidity range. If the product is used outside the specified range for temperature and humidity continuously, it may increase the risk of fire or electric shock. ● Do not place the product at elevations of 1.24 mi. (2,000 m) or higher above sea level. Failure to do so may shorten the life of the internal parts and result in malfunctions. ● When mounting the product into the rack, provide sufficient cooling space. Mount the product in a rack meeting EIA standards, and maintain spaces above and below for air circulation. For your safety as required, attach an L-shaped bracket in addition to the panel mount bracket kit to improve mechanical stability. ● Never insert screws without the rubber feet into the threaded holes on the bottom of the product. Never insert screws without the rubber feet into the threaded holes on the bottom of the product. Doing so may lead to damage when the screws contact electrical circuitry or components inside the product. Reinstall the originally supplied rubber feet using only the originally supplied screws.

■ For operating products:





 <p>Hot surfaces Caution</p>	<p>For products with the hot surfaces caution label only:</p> <ul style="list-style-type: none"> ● Do not touch the product's hot surface. <p>If the product is installed without enough space, it may cause failures of other products operation. If you touch product's hot surface, it may cause burn.</p>
 <p>Prohibited</p>	<ul style="list-style-type: none"> ● Use only the supplied power cable and AC adapter. ● Do not use the supplied power cable and AC adapter with other products. <p>If non-compliant adapter or power cables are used, it may increase the risk of fire or electrical shock.</p>
 <p>Unplug</p>	<ul style="list-style-type: none"> ● If the product won't be used for an extended period of time, unplug it. <p>Failure to observe this precaution may increase the risk of fire.</p> <ul style="list-style-type: none"> ● Unplug the product before cleaning. <p>To prevent electric shock.</p>
 <p>Instruction</p>	<ul style="list-style-type: none"> ● If cooling fan stops, power off the product and contact us. <p>Failure to do so may rise internal temperature and increase the risk of malfunction, fire, or electric shock.</p> <ul style="list-style-type: none"> ● Keep vents clear of dust. <p>If the vent holes near the cooling fan or near the fan are covered with dust, internal temperature rises and it may increase the risk of malfunction. Clean the vent holes and near the fan as needed.</p> <p>If dust accumulates inside of the product, it may increase the risk of malfunction, fire, or electric shock. Periodic internal cleaning, especially before humid rainy season, is recommended. For internal cleaning, contact your IDK representative.</p>

Table of Contents

1	Included items.....	10
2	About IMP-S.....	11
3	Features.....	12
4	Panels.....	13
4.1	Front panel.....	13
4.2	Rear panel.....	14
5	System Configuration Example.....	15
6	Precautions.....	16
6.1	Attaching Rubber feet.....	16
6.2	Installation.....	16
6.3	Cabling.....	17
6.3.1	HDMI cable.....	18
6.3.2	Audio.....	19
6.3.3	Connecting RS-232C cable.....	19
6.3.4	5 V Power output/Contact input/Tally output.....	20
6.3.5	AC adapter with screw locking mechanism.....	23
7	Operation.....	24
7.1	Operation from input selection buttons.....	25
7.1.1	Selecting input channels.....	25
7.1.2	Locking and Unlocking input selection buttons.....	26
7.1.3	Setting sequence switching mode.....	27
7.1.4	Initialization.....	27
7.2	WEB menu operation.....	28
7.2.1	Starting WEB menu.....	29
7.2.2	How to use WEB menu.....	30
7.2.3	Selecting input channels.....	31
7.2.4	Locking and Unlocking input selection buttons.....	32
7.2.5	Setting sequence switching mode.....	33
7.2.6	Editing I/O channels and device names.....	34
7.2.7	Setting automatic reload time of WEB menu.....	34
7.2.8	Saving/Restoring settings.....	35
7.2.9	Initialization.....	36
7.3	Connecting to non-4K-compliant source device.....	37
7.3.1	From selection buttons (EDID changing mode).....	37
7.3.2	Operation from WEB menu.....	39
7.4	Factory default.....	40
8	Configuration and Control.....	42
8.1	WEB menu.....	42
8.2	Automatic input channel switching.....	43
8.2.1	Priority of input channel automatic switching.....	44
8.2.2	Ignoring duration after automatic switching.....	47
8.2.3	Video to be output when input channel is changed OFF to ON.....	47
8.2.4	Sequence switching mode.....	48
8.2.5	Target channels for sequence switching mode.....	50
8.2.6	Switching interval of sequence switching mode.....	50
8.2.7	Input detection.....	50
8.2.8	Start channel of sequence switching mode.....	50

8.3	Input.....	51
8.3.1	No-signal input monitoring	52
8.3.2	HDCP input	53
8.4	Output	54
8.4.1	Output mode	54
8.4.2	Sink device EDID check.....	55
8.4.3	HDCP re-authentication	55
8.5	Audio.....	56
8.5.1	Output mute	56
8.6	Contact input.....	57
8.6.1	Chattering reduction.....	57
8.7	EDID	58
8.7.1	EDID resolution	59
8.7.2	Frame rate.....	63
8.7.3	Deep Color	63
8.7.4	Audio format.....	64
8.7.5	Speaker configuration	65
8.7.6	Copying EDID	65
8.8	RS-232C.....	66
8.8.1	Baud rate.....	67
8.8.2	Data bit length.....	67
8.8.3	Parity check.....	67
8.8.4	Stop bit	67
8.9	LAN.....	68
8.9.1	IP address	69
8.9.2	Subnet mask	69
8.9.3	MAC address	69
8.9.4	TCP port number.....	69
8.10	Startup	70
8.10.1	Start-up input channel.....	71
8.10.2	Button security lockout at startup.....	71
8.11	Advanced settings	72
8.11.1	Beep.....	72
8.11.2	Device information	72
8.12	Status.....	73
8.12.1	Input signal status	74
8.12.2	Sink device status	77
8.12.3	Displaying error message	78
8.12.4	Viewing sink device EDID	80
9	Product Specification	82
9.1	Supported video signals	83
10	Troubleshooting.....	84

1 Included items

Ensure that all items illustrated below are included in the package.
If any items are missing or damaged, please contact IDK.

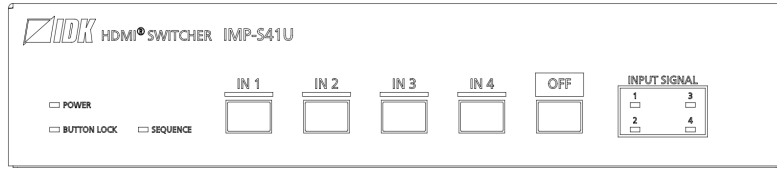

One (1) main unit (IMP-S41U)

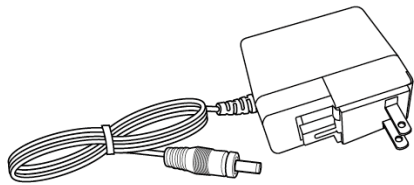

One (1) AC adapter with screw locking mechanism (6 ft. (1.8 m))

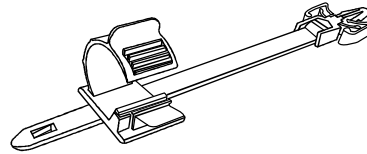

Cable clamps:
Three (3) for IMP-S21U
Five (5) for IMP-S41U

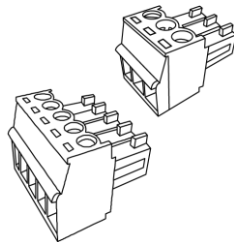

3-pin captive screw connectors:
Five (5) for IMP-S21U
Seven (7) for IMP-S41U
One (1) 5-pin captive screw connector

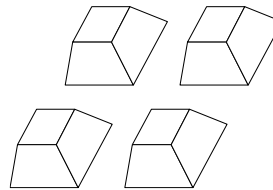

Four (4) Rubber feet

[Fig. 1.1] Included items

2 About IMP-S

The IMP-S series (hereafter referred to as “IMP-S”) is an HDCP 2.2-compliant 4K@60 HDMI switcher with two (2) inputs/four (4) inputs and one (1) output.

Digital audio of selected input channel can be de-embedded to analog audio.

The switcher also includes RS-232C and LAN as communication ports that offer remote setting from WEB browser or control commands. Additionally, contact inputs/tally outputs enable the IMP-S41U to be controlled from the PC I/O board and a control box.

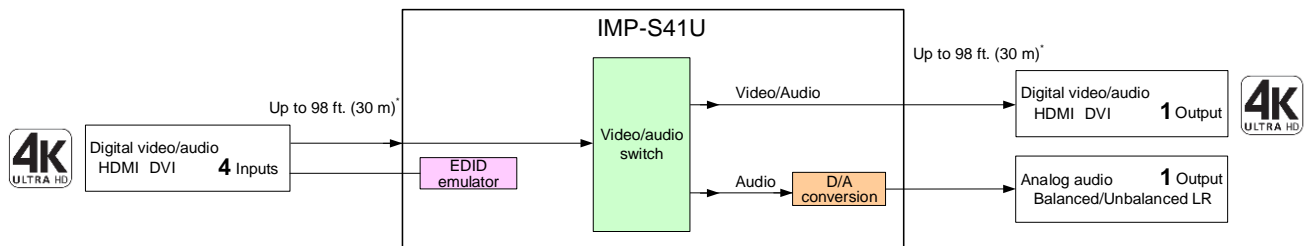

* Maximum transmission distances
 98 ft. (30 m) : 1080p@60
 39 ft. (12m) : 4K@60 (when cable supporting 18 Gbps transmission is used)

[Fig. 2.1] IMP-S41U diagram

3 Features

■ Video

- Up to 4K@60 (4:4:4)
- HDCP 1.4/2.2
- HDR
- 3D
- x.v.Color
- Transmission distance
 - Up to 98 ft. (30 m) : 1080p@60
 - Up to 39 ft. (12 m) : 4K@60 (when cable supporting 18 Gbps transmission is used)
- Anti-snow

■ Audio

- De-embedding

■ Control input

- RS-232C
- LAN
- Contact closure

■ Others

- EDID emulation
- WEB browser control
- Automatic input channel switching
- Input channel sequence switching
- DDC buffer
- Last memory
- Connection Reset
- Button security lockout
- AC adapter with locking mechanism

4 Panels

4.1 Front panel

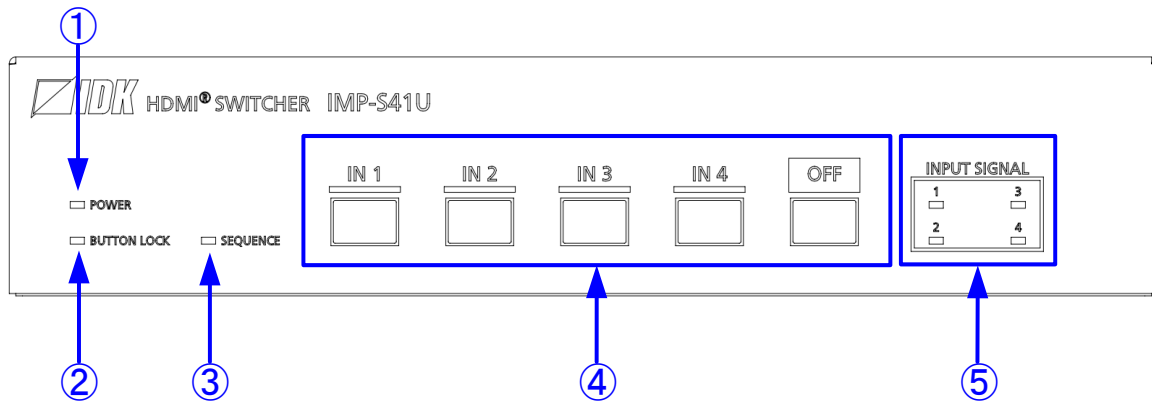

[Fig. 4.1] Front panel drawing (IMP-S41U)

[Table 4.1] Front panel features

#	Feature	Description
①	POWER LED	Shows power status of the IMP-S. Illuminating (green) : Powered ON. Does not illuminate : Powered OFF.
②	BUTTON LOCK LED	Shows lock status of input selection buttons. Illuminating (yellow) : Being locked. Does not illuminate : Lock is released. 【See: 7.1.2 Locking and Unlocking input selection buttons】
③	SEQUENCE LED	Shows execution status of sequence switching mode. Illuminating (yellow) : Being executed. Does not illuminate : The switching mode is released. 【See: 7.1.3 Setting sequence switching mode】
④	Input selection buttons	Selects an input. 【See: 7.1.1 Selecting input channels】
⑤	INPUT SIGNAL LED	Shows input detection of video signal. Illuminating (yellow) : Video signal is input. Does not illuminate : No video signal is input.

4.2 Rear panel

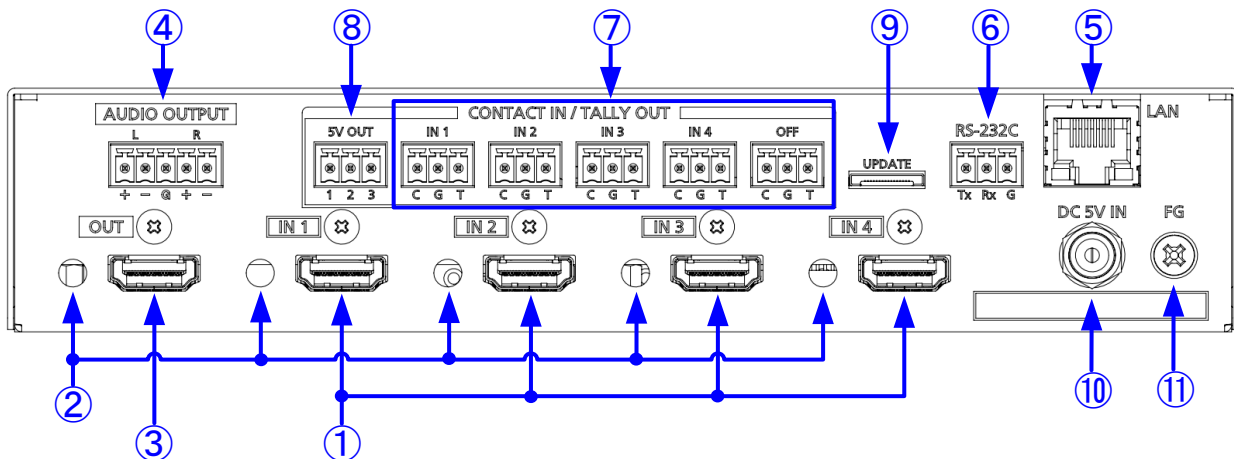

[Fig. 4.2] Rear panel drawing (IMP-S41U)

[Table 4.2] Rear panel features

#	Feature	Description
①	HDMI input connectors	Input connectors for HDMI and DVI signals to interface source devices, such as Blu-ray players
②	HDMI cable fixing holes	Retain HDMI cables by inserting cable clamps. 【See: [Fig. 6.2] Securing and removing cable clamp】
③	HDMI output connector	Output connector for HDMI and DVI signal, interfaces sink devices such as LC monitor and projector
④	AUDIO OUTPUT connector	Analog audio output connector interfaces to amplifier, speaker, or mixer. Digital audio signal that is input from an HDMI input connector will be converted and output. 【See: 6.3.2 Audio】
⑤	LAN connector	For external control by communication commands or web browsers
⑥	RS-232C connector	For external control using communication commands 【See: 6.3.3 Connecting RS-232C cable】
⑦	Contact input/Tally output connectors	Contact input/Tally output connectors For external control using a switch box or the like 【See: 6.3.4 5 V Power output/Contact input/Tally output】
⑧	5 V power output connector	For external Tally LED or the like 【See: 6.3.4 5 V Power output/Contact input/Tally output】
⑨	Maintenance connector	Factory use only
⑩	Power supply connector	For use with supplied AC adapter 【See: 6.3.5 AC adapter with screw locking mechanism】
⑪	Frame ground	Use for bonding chassis to local ground. An M4 screw is used.

5 System Configuration Example

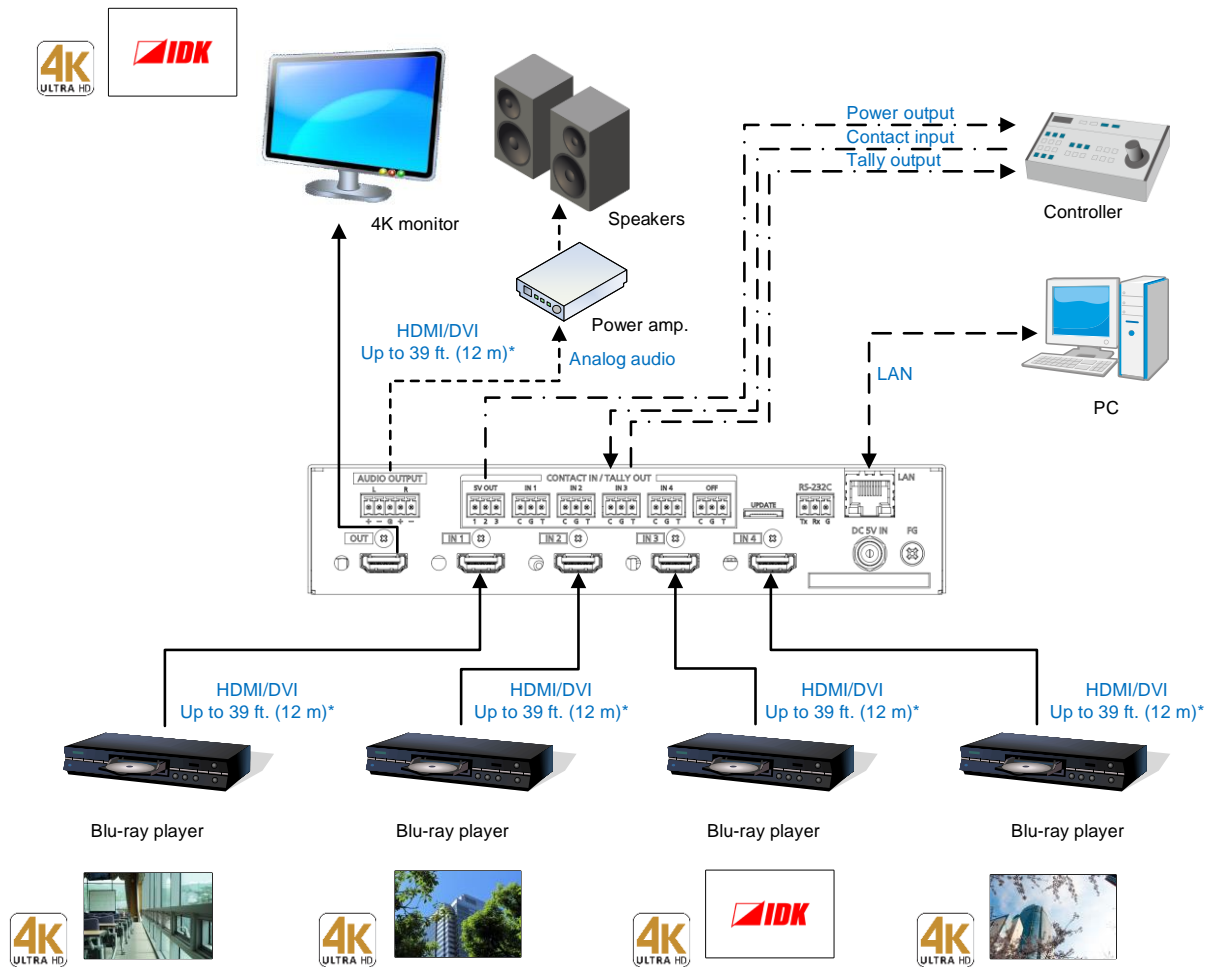

* Maximum transmission distances
 98 ft. (30 m) : 1080p@60
 39 ft. (12m) : 4K@60 (when cable supporting 18 Gbps transmission is used)

[Fig. 5.1] System configuration example

6 Precautions

Before using IMP-S, follow the precautions and instructions below.

6.1 Attaching Rubber feet

First, clean the bottom surface of the IMP-S as needed, and then peel the release papers from the rubber feet and place them in each of the four corners.

6.2 Installation

When installing the IMP-S, observe the following precautions; otherwise, the internal temperature increases and it may affect the product lifetime and operation.

- Do not stack or place one IMP-S directly on top of another IMP-S.
- Do not block vent holes.

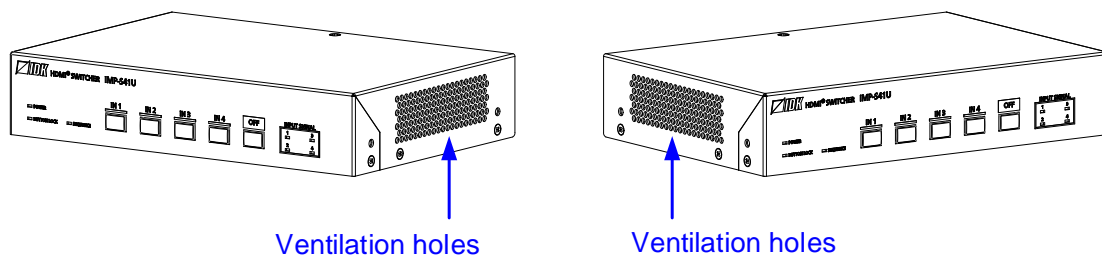

[Fig. 6.1] Ventilation holes (IMP-S41U)

- To provide adequate ventilation, maintain sufficient clearances around the IMP-S (1.2 in. (30 mm) or more).
- Consider installing the IMP-S in an environment compatible with the maximum temperature indicated in the specification sheet 32°F to 104°F (0°C to +40°C).

Tip:

For installing the IMP-S in an EIA rack, we offer optional rack mounting hardware. Please contact us as needed.

6.3 Cabling

When connecting the IMP-S to external devices, observe the following precautions.

- Read manuals for the external devices.
- Before connecting cables to the IMP-S or an external device, dissipate static electricity by touching grounded metal such as equipment racks before handling signal cables. Failure to observe this precaution may result in ESD (electrostatic discharge) damage.
- Power all units off before connecting cables.
- Be sure to fully seat all plugs and connections and dress cables to reduce stress on connectors.
- Secure HDMI cables using cable clamps to prevent connectors from being accidentally pulled out of ports.

Securing HDMI cable using cable clamp

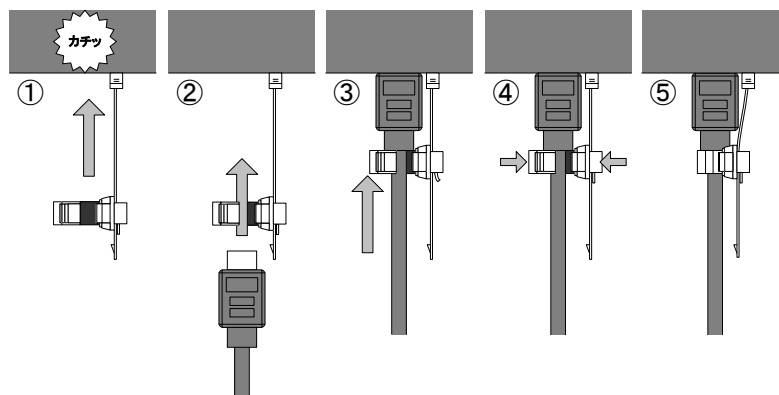

Removing HDMI cable and cable clamp

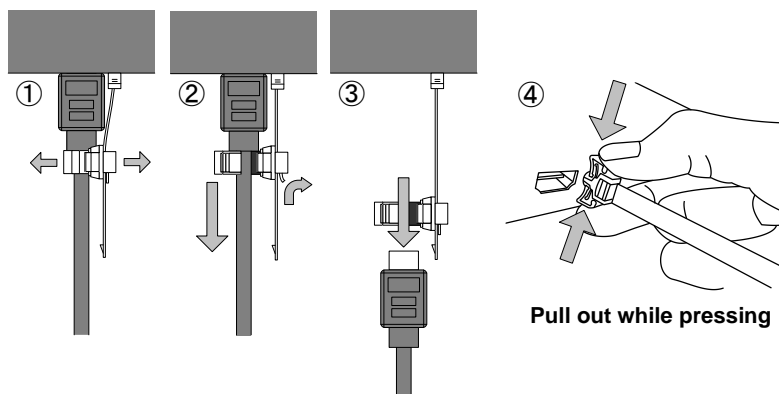

[Fig. 6.2] Securing and removing cable clamp

6.3.1 HDMI cable

When the video is 4K format, the maximum TMDS data rate (transmission speed) is 18 Gbps. If a high-speed HDMI cable is used, the maximum TMDS data rate of 10.2 Gbps can be transferred, and the video cannot be displayed stably.

Please select an 18 Gbps high-speed cable depending on the 4K format. The maximum transmission distance depends on the cable type, source and sink devices. You are recommended to use high quality cables.

[Table 6.1] 18 Gbps high-speed cable for 4K format

	TMDS data rate (Gbps)								
	RGB, YCbCr 4:4:4			YCbCr 4:2:2			YCbCr 4:2:0		
4K format	24 bit	30 bit	36 bit	24 bit	30 bit	36 bit	24 bit	30 bit	36 bit
3840x2160p (24/25/30)	10.2 Gbps	18 Gbps	18 Gbps	10.2 Gbps	10.2 Gbps	10.2 Gbps	—	—	—
4096x2160 (24/25/30)	10.2 Gbps	18 Gbps	18 Gbps	10.2 Gbps	10.2 Gbps	10.2 Gbps	—	—	—
3840x2160p (50/59.94/60)	18 Gbps	—	—	18 Gbps	18 Gbps	18 Gbps	10.2 Gbps	18 Gbps	18 Gbps
4096x2160 (50/59.94/60)	18 Gbps	—	—	18 Gbps	18 Gbps	18 Gbps	10.2 Gbps	18 Gbps	18 Gbps

18 Gbps: 18 Gbps high-speed cable, 10.2 Gbps: 10.2 Gbps transmission cable, —:N/A

Note:

If a cable joint (JJ) or the like is used to extend the distance, the video may not be displayed correctly.

6.3.2 Audio

Connect the supplied 5-pin captive screw connector to the IMP-S. The IMP-S supports both balanced and unbalanced signals.

28 AWG to 16 AWG conductor gauge and a strip length of 0.28 in. (7 mm) are recommended.

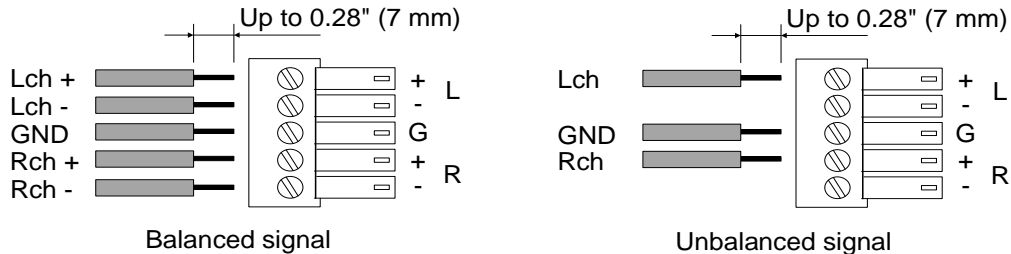

[Fig. 6.3] Connecting audio cable to 5-pin captive screw connector

Notes:

- The output level of balance signal connection is twice as much as that of unbalanced signal connection.
- When input level of digital audio is 0 dBFS, output levels of analog audio unbalanced and balanced signals are 10 dBu and 16 dBu, respectively.

6.3.3 Connecting RS-232C cable

Insert and secure the wires from the RS-232C cable into the supplied 3-pin captive screw connector, and then insert the captive screw connector into the mating connector on the IMP-S.

28 AWG to 16 AWG conductor gauge is recommended.

The recommended wire strip length is 0.28 in. (7 mm).

Short RTS/CTS and DTR/DSR as needed.

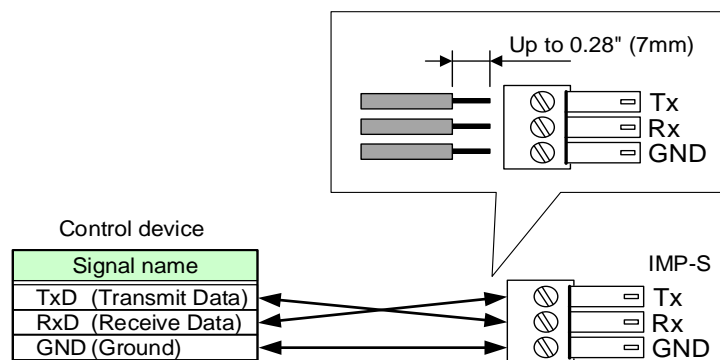

[Fig. 6.4] Connecting RS-232C cable to 3-pin captive screw connector

6.3.4 5 V Power output/Contact input/Tally output

The IMP-S has contact input/tally output connector as external control interface which enables control from PC's I/O board and remote operation from a switch box.

A 5 V power output connector is included for Tally LED.

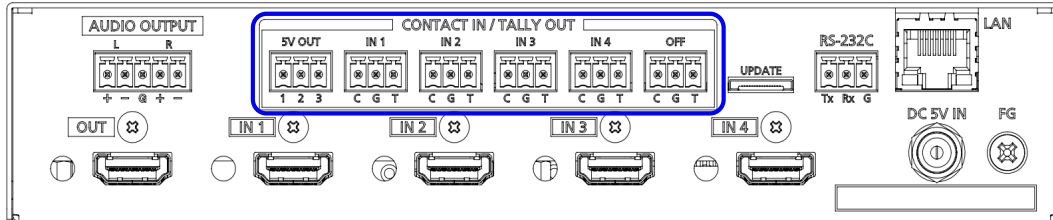

[Fig. 6.5] 5 V Power output/Contact input/Tally output connectors (IMP-S41U)

■ Pin assignment

[Table 6.2] Pin assignments of 5 V Power output connector, Contact input/Tally output connector (IMP-S41U)

Connector	Pin #	Terminal	Feature
5V OUT	1	LED300	DC 5 V output (with 300 Ω current-limiting resistor)
	2	LED75	DC 5 V output (with 75 Ω current-limiting resistor)
	3	VCC 5 V	DC 5 V output (500 mA, rated)
IN1	C	Contact input	When 0 V (GND) is input, IN1 will be selected.
	G	GND	—
	T	Tally output	When IN1 is selected, 0 V (GND) is output.
IN2	C	Contact input	When 0 V (GND) is input, IN2 will be selected.
	G	GND	—
	T	Tally output	When IN2 is selected, 0V (GND) is output.
IN3	C	Contact input	When 0 V (GND) is input, IN3 will be selected.
	G	GND	—
	T	Tally output	When IN3 is selected, 0 V (GND) is output.
IN4	C	Contact input	When 0 V (GND) is input, IN4 will be selected.
	G	GND	—
	T	Tally output	When IN4 is selected, 0V (GND) is output.
OFF	C	Contact input	When 0 V (GND) is input, OFF will be selected.
	G	GND	—
	T	Tally output	When OFF is selected, 0 V (GND) is output.

■ Controlling contact input

Input channel of the IMP-S can be switched remotely by using contact input.

Please ground the contact input terminal of the desired input channel to switch the input channel.

After the GND is connected, keep it back to the open state. If using a press-type switch to control contact input, select a toggle type switch (pressing: ON; releasing: OFF).

If chattering makes the operation unstable, set the removing chattering time longer in “**8.6.1 Chattering reduction**”.

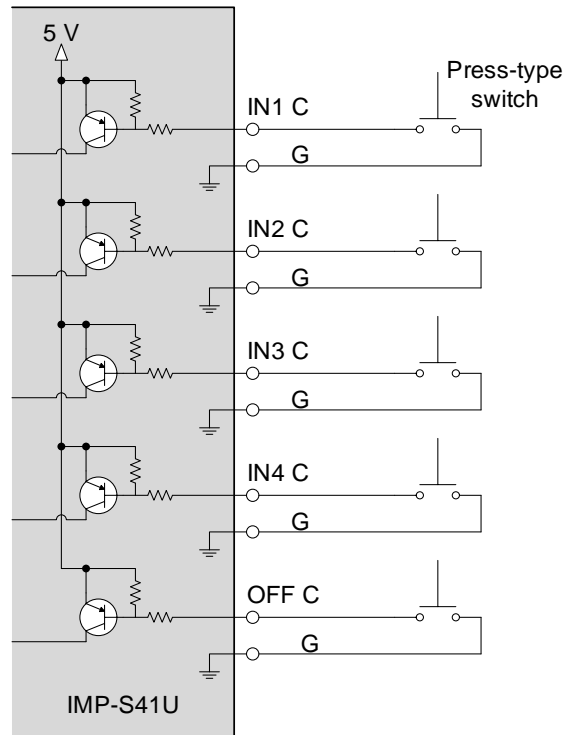

[Fig. 6.6] Circuit example of contact input (IMP-S41U)

Notes:

- Keep unused contact input terminals open.
- For electrical control, the range should be DC 0 V to 5 V \pm 5%.
- For controlling signal to contact input, please input pulse signal.

Controlling Tally output

In order to illuminate the LED of the selected input selection button, form the circuit as follows.

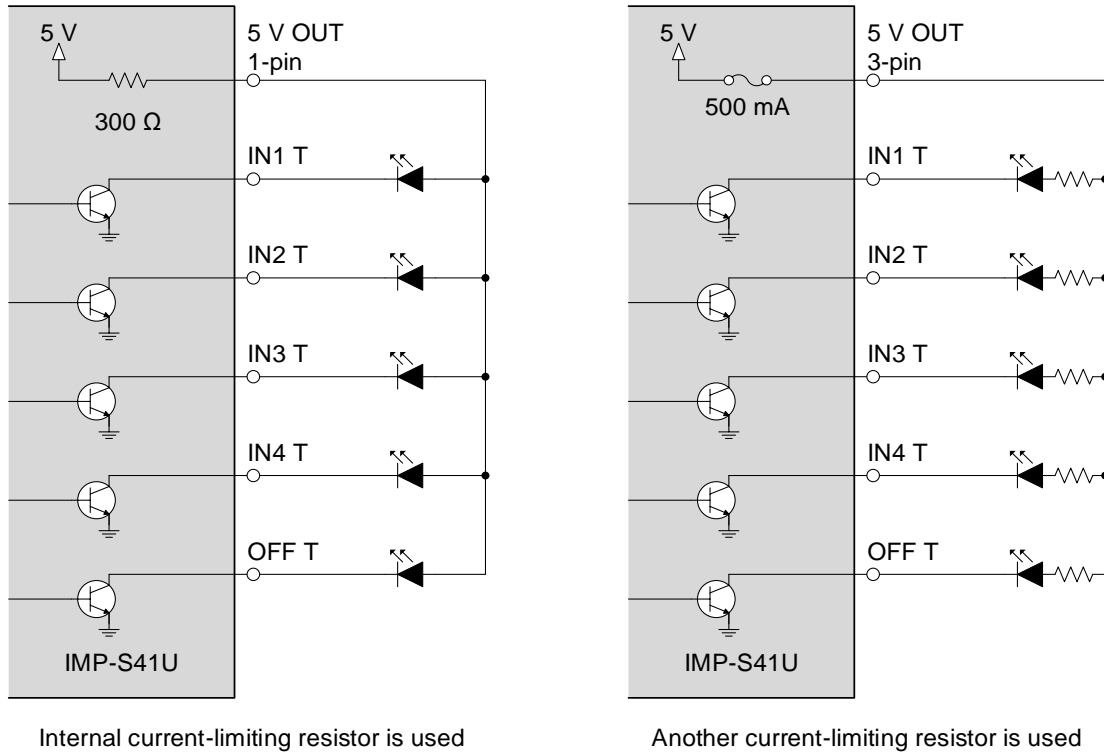

[Fig. 6.7] Tally output circuit example (IMP-S41U)

Notes:

- Keep unused contact input terminals open.
- Before using DC 5 V output and current-limiting resistor, check the specification of the LED.
- The maximum load capacity of Tally output is DC 48 V 1 A.

Cabling (5 V Power output connector, Contact input/Tally output connector)

Attach a cable to the provided 3-pin captive screw connector and connect it to a 5 V Power output connector, Contact input/Tally output connector.
 28 AWG to 16 AWG conductor gauge is recommended.
 The recommended wire strip length is 0.28 in. (7 mm).

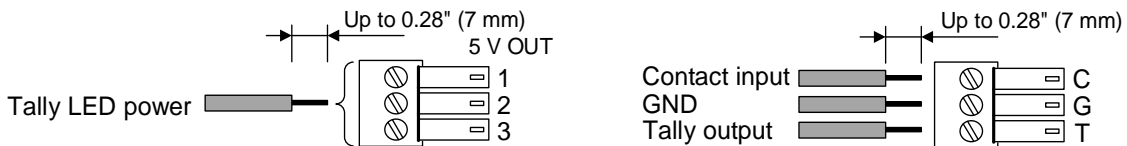

[Fig. 6.8] Connecting 5 V Power output cable/Contact input/Tally output cable to 3-pin captive screw connector

6.3.5 AC adapter with screw locking mechanism

The shapes of AC plugs with screw locking mechanism vary from country to country. The AC plug can be removed from the AC adapter.

Removing AC plug:

Slide the AC plug (②) from the AC adapter while holding down the portion mentioned below (①).

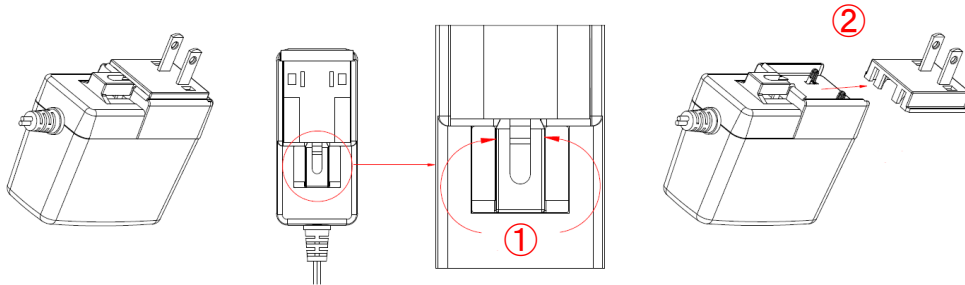

[Fig. 6.9] Removing AC plug (Example: Plug type A)

Attaching AC plug:

Gently slide the AC plug into the AC adapter (③) until it clicks (④).

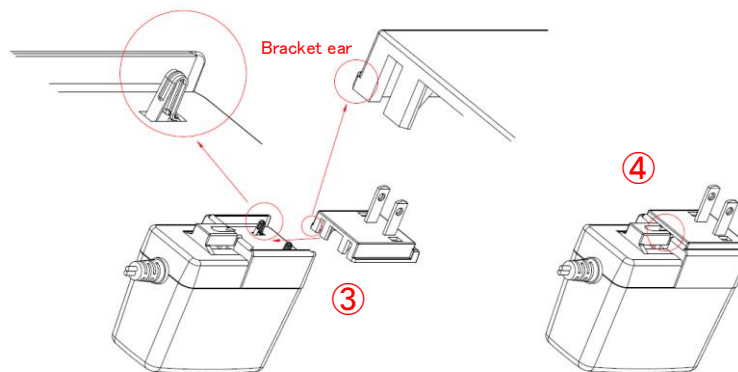

[Fig. 6.10] Attaching AC plug (Example: Plug type A)

Connect the supplied AC adapter to the power supply connector and screw the DC plug.

7 Operation

The IMP-S can be controlled from input selection buttons, WEB menu, or communication commands. In this chapter, basic operations using input election buttons and WEB menu.

[Table 7.1] Basic operation

Operation	Input selection buttons	WEB menu	Communication command
Selecting input channels	Y	Y	Y
Locking and Unlocking input selection buttons	Y	Y	Y
Setting sequence switching mode	Y	Y	Y
Changing EDID resolution	Y*	Y	Y
Setting buzzer tone of input selection buttons	N	Y	Y
Saving/Restoring settings	N	Y	N
Initialization	Y	Y	N
Other settings	N	Y	Y
Reference	7.1 (P.25) 7.3 (P.37)	7.2 (P.28) 7.3 (P.37) 8 (P.42)	7.3 (P.37) Command Guide

Y: Can be performed; N: Cannot be performed

*EDID resolution can be changed by switching the mode to EDID changing mode.

【See: 7.3.1 From selection buttons (EDID changing mode)】

■ Powering up period

After powering on the IMP-S from a power-off condition, there is a short initialization delay before the first communication command can be received and executed. Predictable behavior during power up can be maintained by observing the recommended delay periods listed below.

[Table 7.2] Power up period

Operation	Delay period
Receiving communication command	4 seconds
Receiving WEB browser operation	4 seconds
Receiving contact input	6 seconds
Receiving front panel operation	6 seconds

7.1 Operation from input selection buttons

- Selecting input channels
- Locking and Unlocking input selection buttons
- Setting sequence switching mode
- Initialization

Tip:

You will hear a short beep tone when pressing available buttons (by default).

【See: 8.11.1 Beep】

7.1.1 Selecting input channels

Press the desired input selection button to the output video and audio signals.

Press the “OFF” button to disable video and audio signal output.

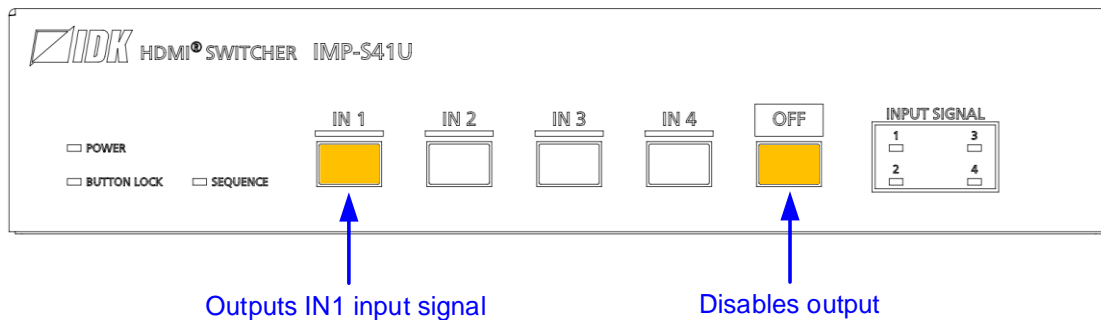

[Fig. 7.1] Selecting input channel (IMP-S41U)

Tip:

Once the input channel with HDCP is selected, the HDCP authentication status of the output channel is kept. The switching time can be shortened by skipping re-HDCP authentication at the time of switching.

However, HDCP authentication will be canceled when the IMP-S is rebooted or a cable is unplugged.

7.1.2 Locking and Unlocking input selection buttons

Press and hold “IN1” for 3 seconds or longer to lock/unlock input selection button.

Press and hold “IN1” for 3 seconds or longer to lock button. When a button is locked, you hear a long beep tone and the “BUTTON LOCK” LED lights yellow.

Locked input selection buttons cannot be operated except for “IN1” which is used for unlocking

Press and hold “IN1” for 3 seconds or longer to unlock the button. When a button is unlocked, you hear a long beep tone and the BUTTON LOCK LED turns off.

The IMP-S starts with the status that is set in “8.10.2 Button security lockout at startup”.

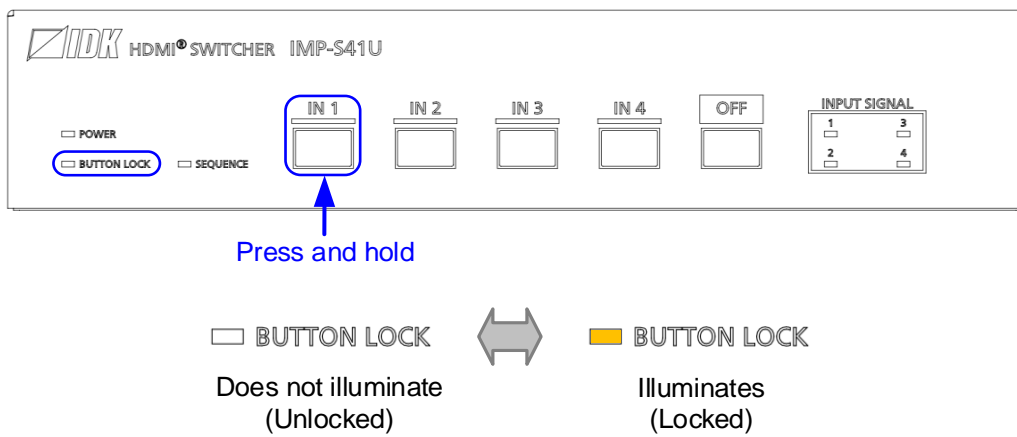

[Fig. 7.2] Locking and unlocking input selection buttons (IMP-S41U)

7.1.3 Setting sequence switching mode

Press and hold the “IN2” button for 3 seconds or longer to enable/disable sequence switching mode which switches input channels automatically at the desired interval.

The “SEQUENCE” LED illuminates yellow while sequence switching mode is enabled.

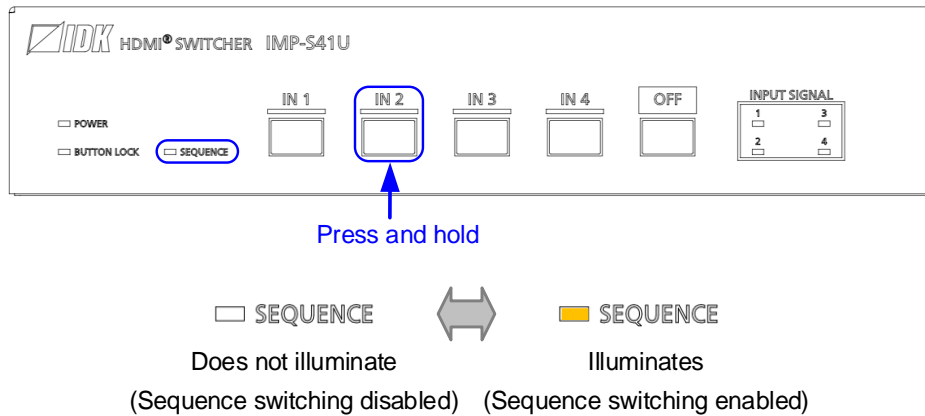

[Fig. 7.3] Setting sequence switching mode (IMP-S41U)

【See: 8.2.4 Sequence switching mode】

Tip:

If sequence switching mode is enabled, input channel is not switched even using input channel selection button.

7.1.4 Initialization

All settings will be initialized to factory default values by powering on the IMP-S while pressing and holding the “OFF” button.

Press and hold the “OFF” button until you hear a long beep sound.

Note that once settings are initialized, they cannot be restored again.

【See: 7.4 Factory default】

Note that after resetting to factory defaults, the previous setting values cannot be restored.

【See: 7.2.8 Saving/Restoring settings】

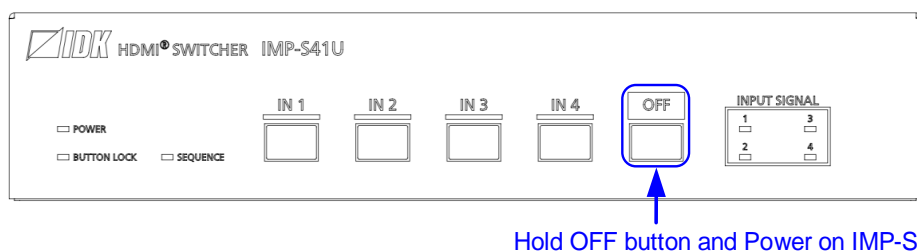

[Fig. 7.4] Initialization (IMP-S41U)

7.2 WEB menu operation

All settings of the IMP-S that is connected to LAN can be controlled by WEB menu operation over WEB browser.

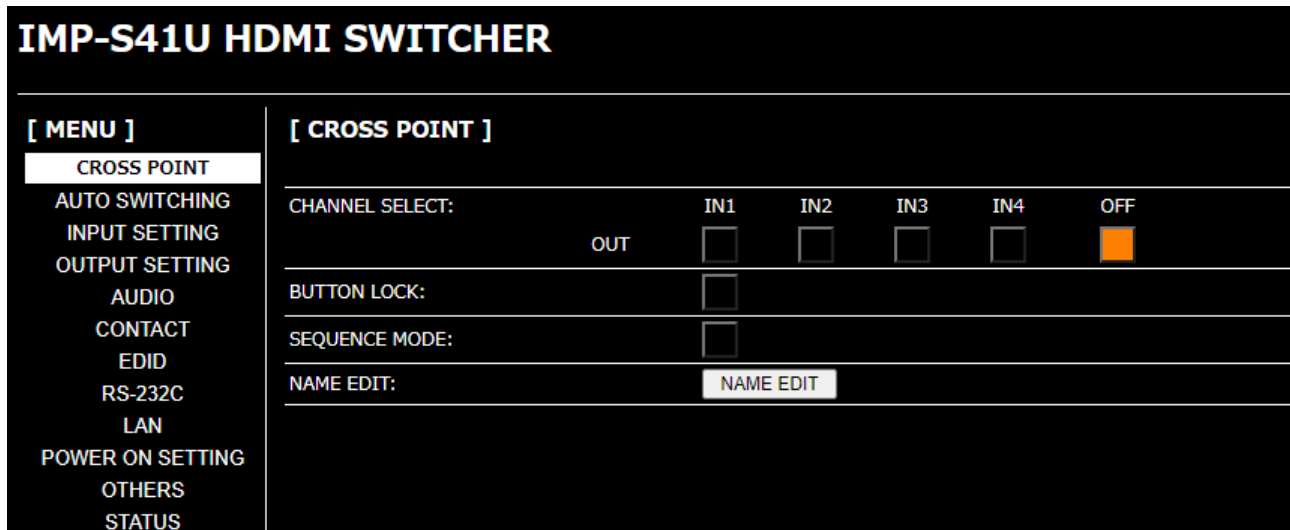

[Fig. 7.5] WEB menu (IMP-S41U)

- Selecting input channels
- Locking and Unlocking input selection buttons
- Setting sequence switching mode
- Editing I/O channels and device names
- Setting automatic reload time of WEB menu
- Saving/Restoring settings
- Initialization

Ensure that LAN communication between the control device and the IMP-S and JavaScript are enabled. Refer to each browser's help menu if you do not know how to enable JavaScript.

7.2.1 Starting WEB menu

Enter the set IP address into the address bar in order to display the WEB menu.

【See: 8.9.1 IP address】

【See: 8.9.4 TCP port number】

[Table 7.3] Example URL

Port number of WEB browser	URL to be entered into address bars
80 (Normal)	http://192.168.1.199
Other than 80 (5000 to 5999)	http://192.168.1.199:5000 (e.g. #5000)

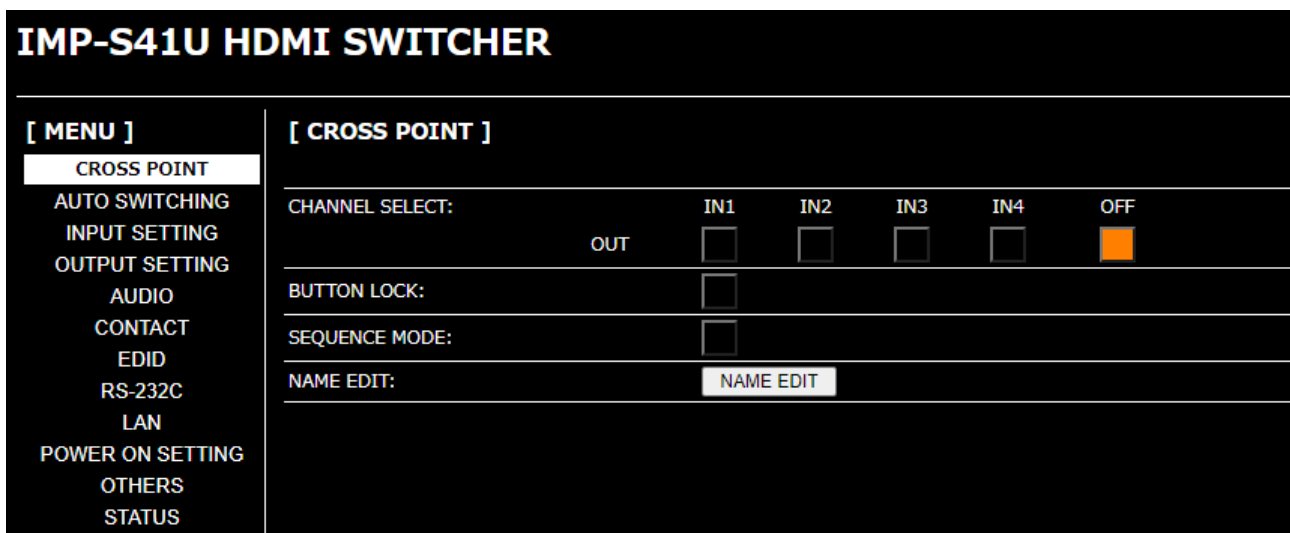
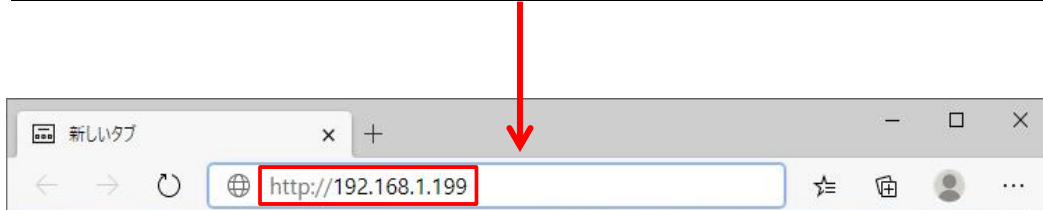

[Fig. 7.6] Top menu WEB (IMP-S41U)

7.2.2 How to use WEB menu

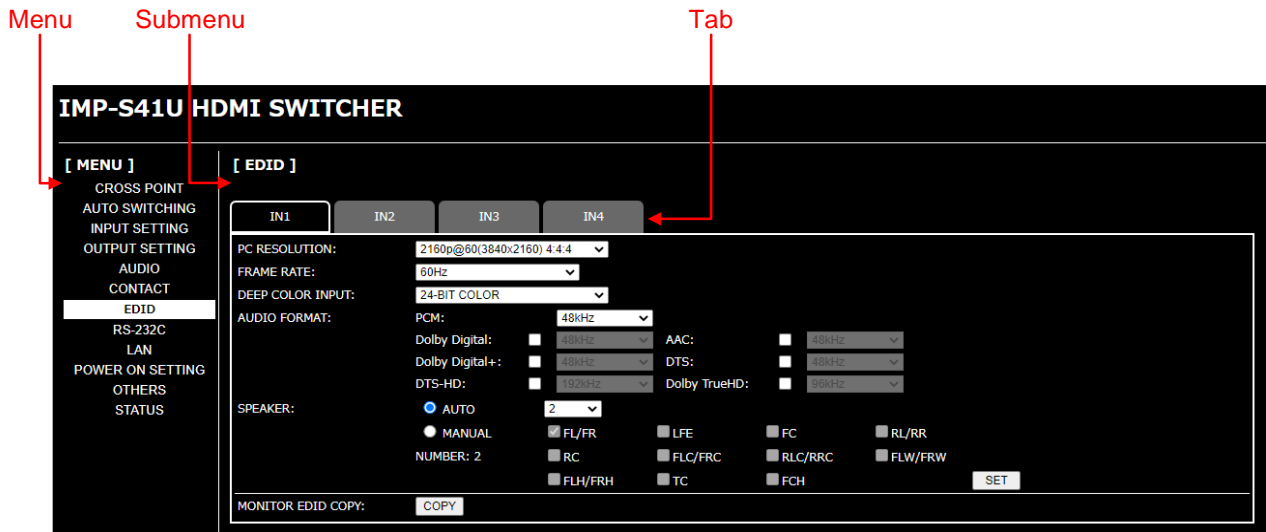

[Fig. 7.7] WEB menu (IMP-S41U)

- ① Select the desired menu. The setting items will be displayed in the submenu.
- ② For some menus, you can select channels by clicking the desired tab.
- ③ Menus for the selected tab are displayed.
For form controls, see the table below.

[Table 7.4] Menu page item

Form control	Example	Description
Set/execution button		Executes the desired operation.
Pull down list		Selects a setting value from multiple setting values.
Arrow button		Selects a setting value from the range. You also can set a value by entering the value directly.
Slider bar		Selects a setting value from the wide range.
Check box		Enables and disables by clicking or unclicking the box.
Radio button		Selects a setting value from multiple setting values.

7.2.3 Selecting input channels

Select output channels from [CROSS POINT] > [CHANNEL SELECT]. Click the “OFF” button to disable video and audio signal output.

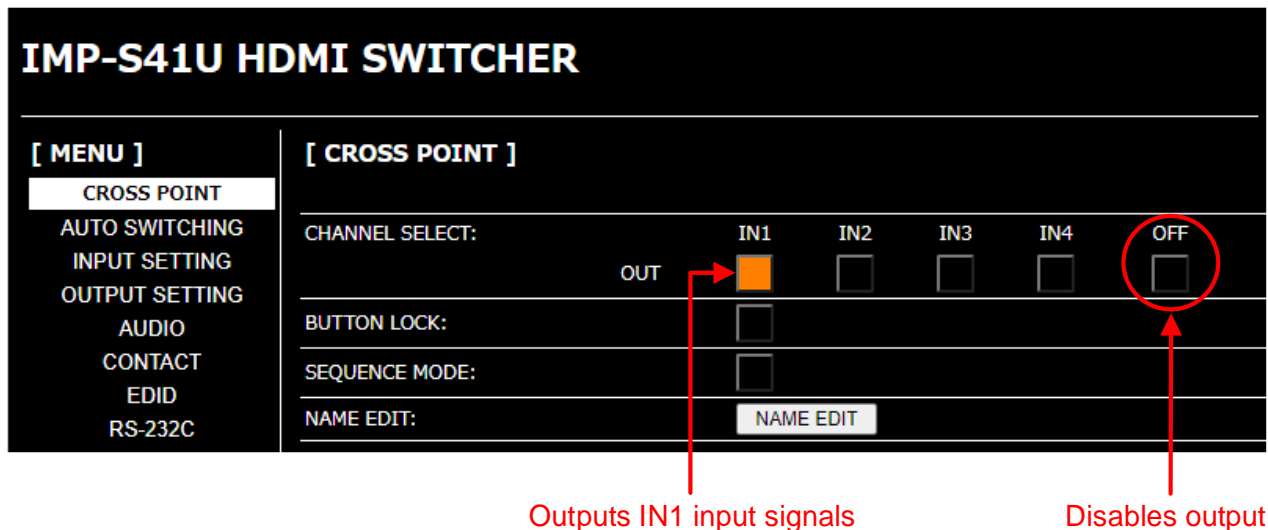

[Fig. 7.8] Selecting input channel (IMP-S41U)

Tip:

Once the input channel with HDCP is selected, the HDCP authentication status of the output channel is kept. The switching time can be shortened by skipping re-HDCP authentication at the time of switching. However, HDCP authentication will be canceled when the IMP-S is rebooted or a cable is unplugged.

【See: 7.1.1 Selecting input channels】

7.2.4 Locking and Unlocking input selection buttons

[CROSS POINT] > [BUTTON LOCK]

Click [BUTTON LOCK] to lock front buttons. The button will light yellow. Operations cannot be performed from the buttons while they are locked; except for [IN1] for unlocking the buttons.

Click [BUTTON LOCK] again to unlock the front buttons.

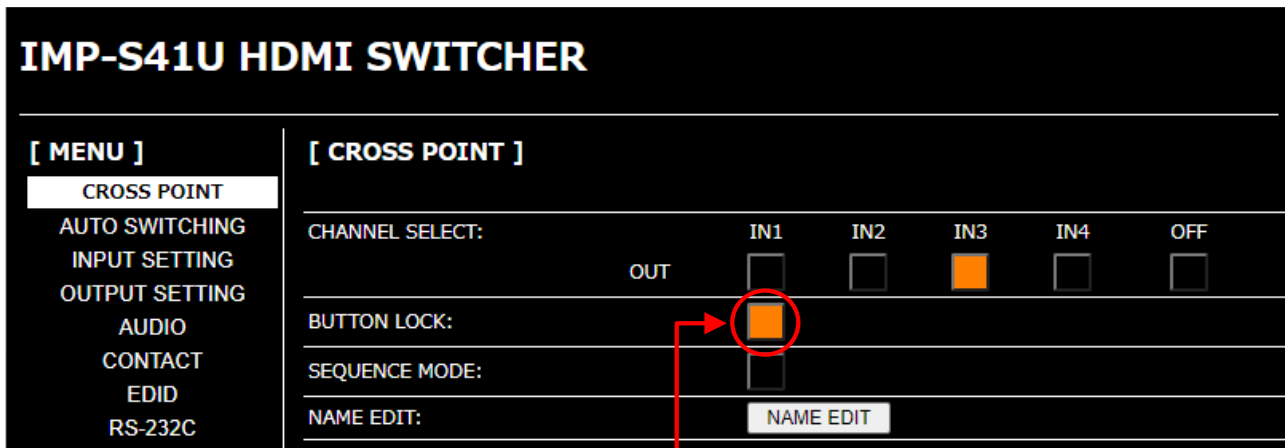

Lights yellow : Locked
Does not light : Unlocked

[Fig. 7.9] Locking and unlocking input selection buttons (IMP-S41U)

【See: 7.1.2 Locking and Unlocking input selection buttons】

7.2.5 Setting sequence switching mode

[CROSS POINT] > [SEQUENCE MODE]

Input channel can be switched automatically at the desired interval.

Click [SEQUENCE MODE] to switch input channels according to the [AUTO SWITCHING] settings.
The button will light yellow.

Click [SEQUENCE MODE] again to disable the sequence switching mode.

【See: 8.2.4 Sequence switching mode】

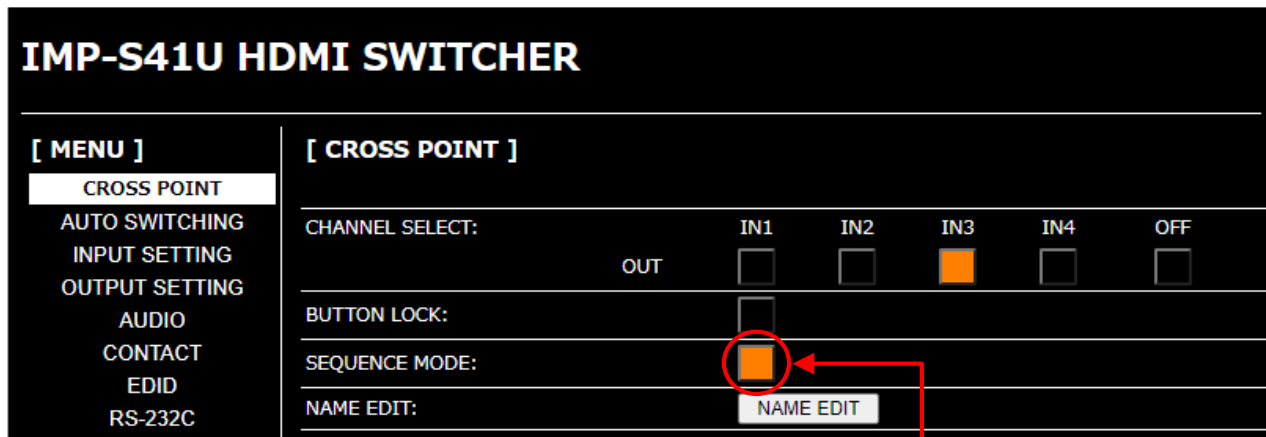

Lights yellow : ON
Does not light : OFF

[AUTO SWITCHING] menu

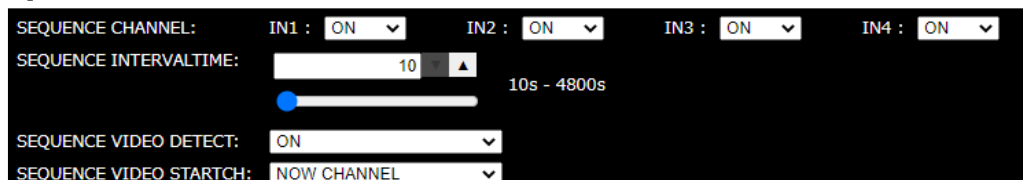

[Fig. 7.10] Setting sequence switching mode (IMP-S41U)

Tip:

If sequence switching mode is enabled, input channel is not switched even using input channel selection button.

7.2.6 Editing I/O channels and device names

[CROSS POINT] > [NAME EDIT]

I/O channels: Up to 10 one-byte characters

Device : Up to 40 one-byte characters

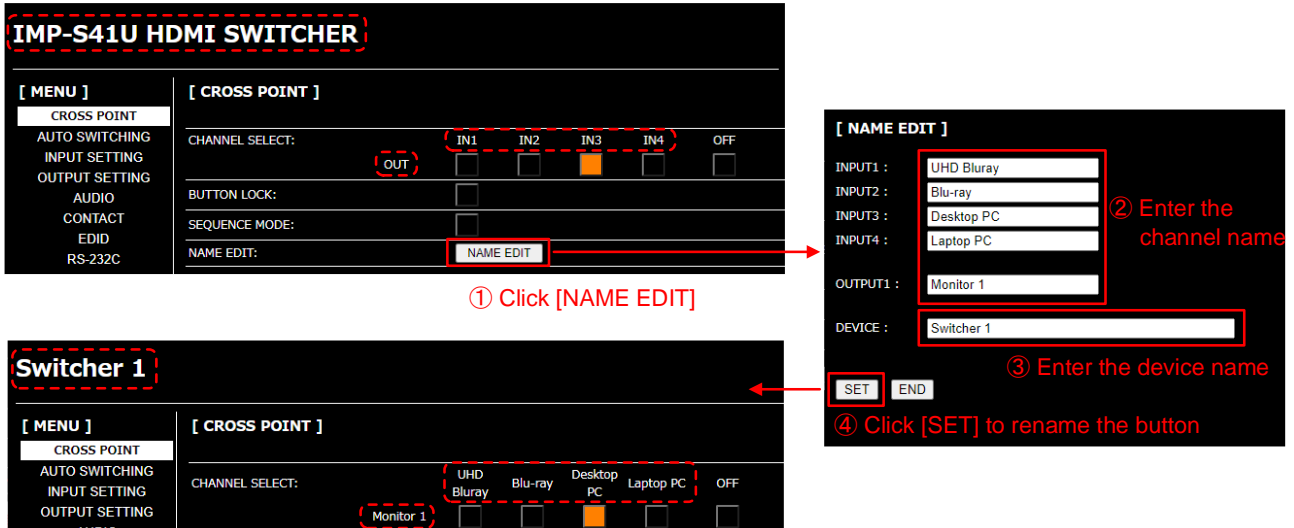

[Fig. 7.11] Editing name (IMP-S41U)

7.2.7 Setting automatic reload time of WEB menu

[OTHERS] > [AUTO RELOAD TIME]

[OFF] : Not reloaded the WEB menu automatically. [Default]

[1] to [10] sec. : Reloaded [CROSS POINT] and [STATUS] automatically at the selected interval.

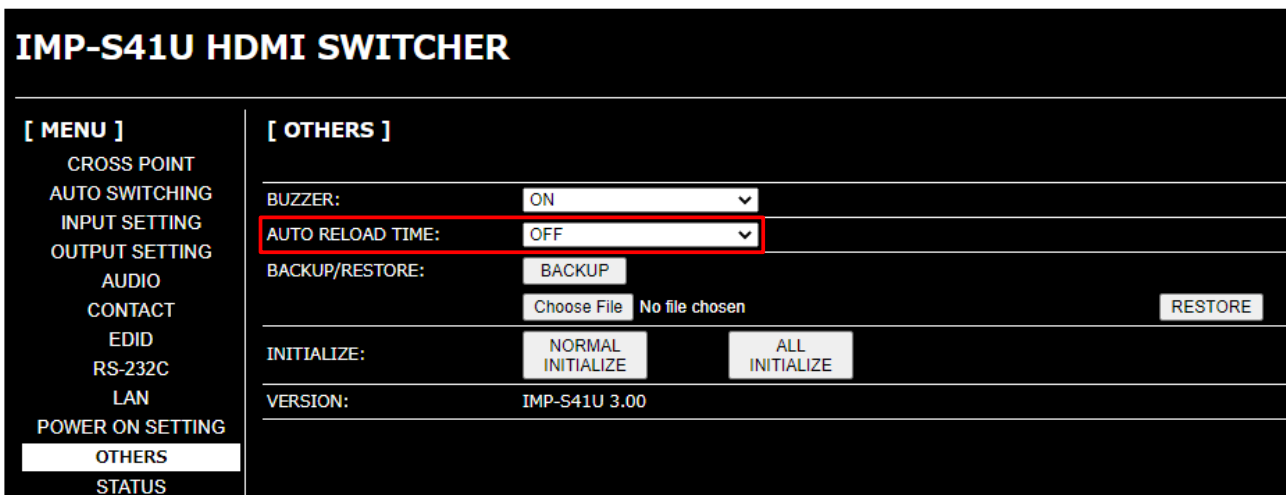

[Fig. 7.12] Setting automatic reload time (IMP-S41U)

7.2.8 Saving/Restoring settings

To save saved settings to a PC as a backup file:

1. Select [OTHERS] from [MENU].
2. Click the [BACKUP] button of [BACKUP/RESTORE].
3. When the confirmation message appears, click the [OK] button.

The backup file is saved with a “.idm” extension to the PC. This name can be edited later.

IMP-S21U ... imp-s21u.idm

IMP-S41U ... imp-s41u.idm

To restore settings from PC:

1. Select [OTHERS] from [MENU].
2. Select a file from [Choose File].
3. Click the [RESTORE] button of [BACKUP/RESTORE].

Do not perform other WEB operations or power off the IMP-S during the operation.

4. If the restoration fails, an alert dialog appears during the operation.

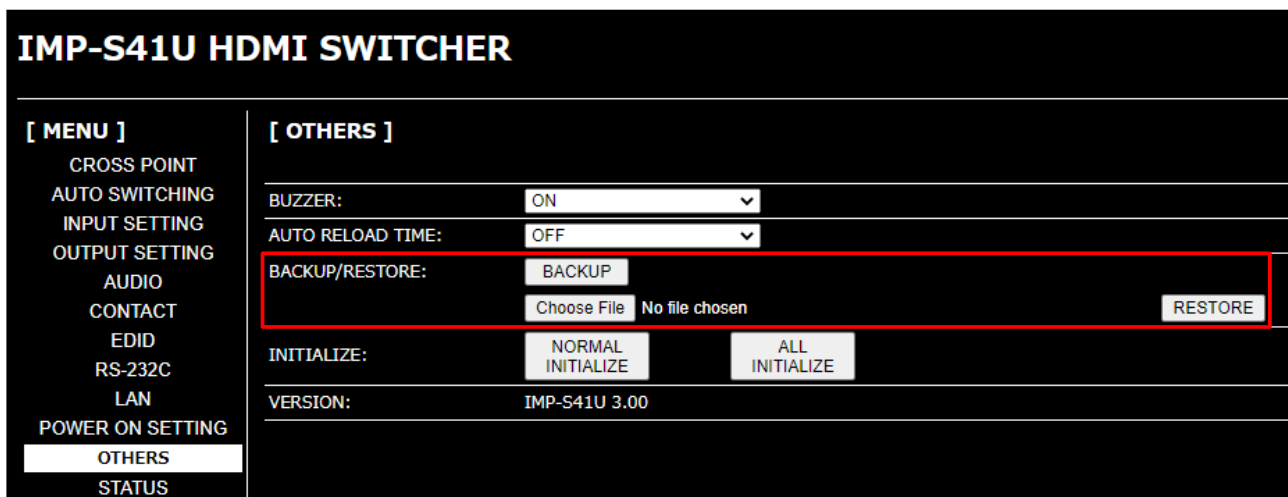

[Fig. 7.13] Saving/Restoring settings (IMP-S41U)

7.2.9 Initialization

To reset the IMP-S to factory defaults:

1. Select [OTHERS] from [MENU].
2. For initializing settings except LAN communication settings: Click the [NORMAL INITIALIZE] button.
For initializing all settings including the communication settings: Click the [ALL INITIALIZE] button.

【See: 7.4 Factory default】

Note that after resetting to factory defaults, the previous setting values cannot be restored.

【See: 7.2.8 Saving/Restoring settings】

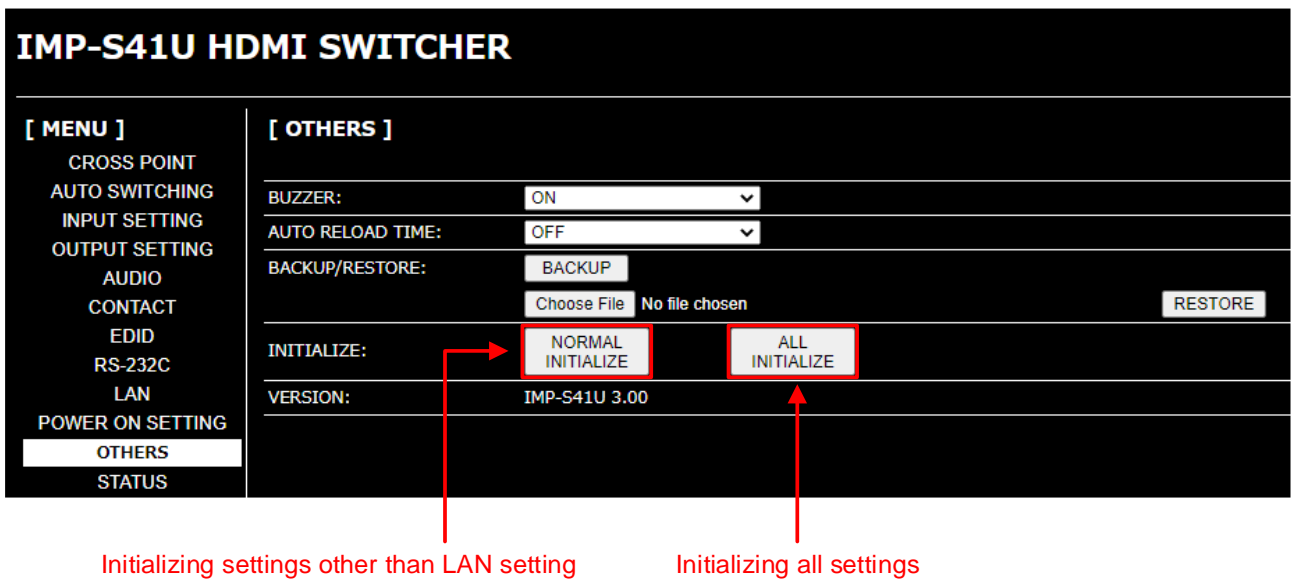

[Fig. 7.14] Initialization (IMP-S41U)

7.3 Connecting to non-4K-compliant source device

If connecting to a source device that does not support 4K, video may not be output because the built-in EDID is set to “2160p@60 (3840x2160) 4:4:4” by default. Change the EDID in order to output HDMI signals from input selection buttons, WEB menu, or commands.

【See: 8.7.1 EDID resolution】

7.3.1 From selection buttons (EDID changing mode)

Press and hold “IN1”, “IN2”, and “OFF” buttons for five seconds until you hear the beep tones in order to enable EDID changing mode (“2160p@60(3840x2160) 4:4:4” or “1080p@60(1920x1080”).

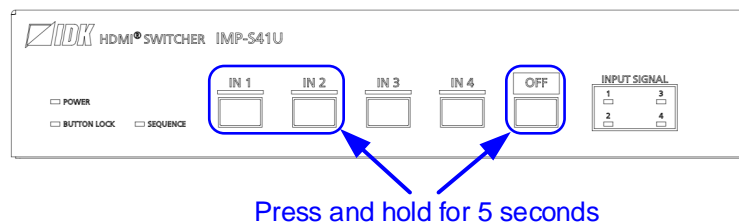

【Fig. 7.15】 EDID changing mode (IMP-S14U)

■ Checking current EDID resolution

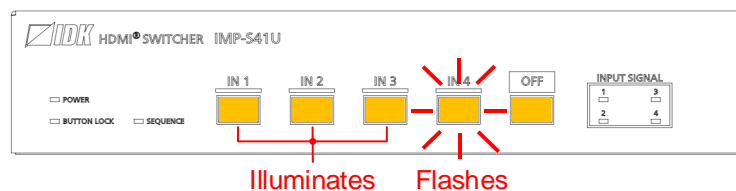

【Fig. 7.16】 Button status for EDID resolution (IMP-S41U)

【Table 7.5】 Current EDID resolution

Button	Current EDID resolution
Illuminates	<ul style="list-style-type: none"> ▪ 2160p@30(3840x2160) to 4096x2160@60 4:4:4 ▪ EXTERNAL (External EDID) ▪ COPY EDID
Flashes	Resolutions other than 4K (SVGA to WQXGA)

■ **Changing EDID resolution**

Selecting “2160p@60 (3840x2160) 4:4:4”:

Press the desired flashing input selection button.

Selecting “1080p@60 (1920x1080)”:

Press the desired illuminating input selection button.

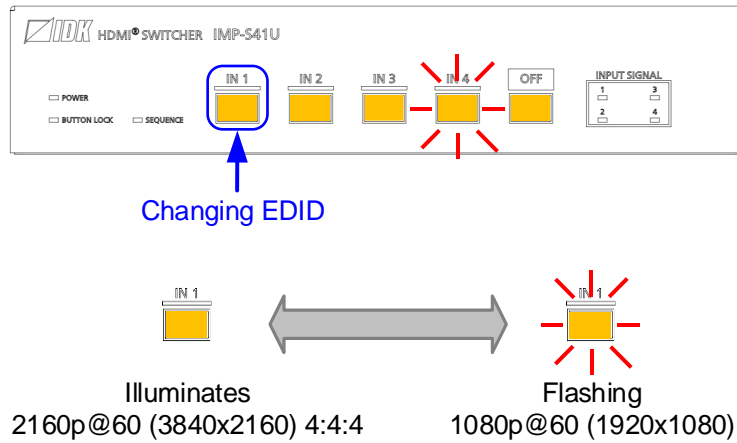

[Fig. 7.17] Changing EDID resolution (IMP-S41U)

Tip:

To select a resolution other than “2160p@60 (3840x2160) 4:4:4” and “1080p@60 (1920x1080)”, change the setting from WEB menu or the command.

【See: 7.3.2 Operation from WEB menu】

Disabling EDID changing mode

Click the “OFF” button, you will hear a beep tone.

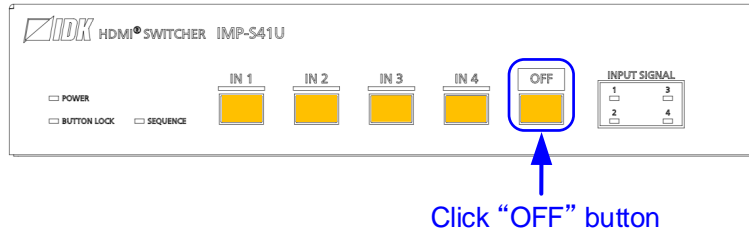

[Fig. 7.18] Disabling EDID changing mode (IMP-S41U)

Tip:

If you do not operate these buttons for 10 seconds, the EDID changing mode will be disabled.

Note:

When EDID changing mode is disabled, the previous and current selected channels may not be the same. In such cases, select the desired channel again.

7.3.2 Operation from WEB menu

Set the EDID resolution from [EDID] > [PC RESOLUTION].

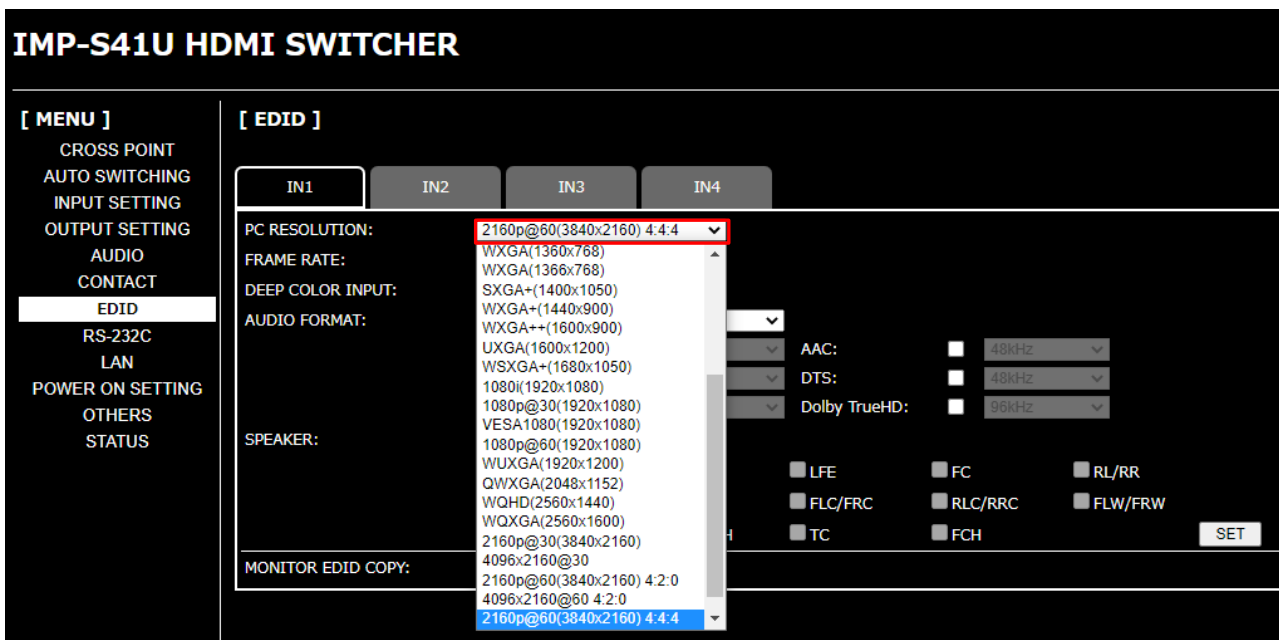

[Fig. 7.19] Changing EDID from WEB menu (IMP-S41U)

7.4 Factory default

[Table 7.6] Factory default (1/2)

Setting	Factory default	See
Selecting input channels		
Selecting input channels	OFF	25
Locking and Unlocking input selection buttons		
Locking and Unlocking input selection buttons	Unlocked	32
Automatic input channel switching		
Priority of input channel automatic switching	OFF	44
Ignoring duration after automatic switching	0 sec.	47
Video to be output when input channel is changed OFF to ON	Black image is output.	47
Sequence switching mode	OFF	48
Target channels for sequence switching mode	IN1 to IN4 are switched	50
Switching interval of sequence switching mode	10 sec.	50
Input detection	Only input channels in which video signal is detected will be switched.	50
Start channel of sequence switching mode	Starts from the current input channel.	50
Input		
No-signal input monitoring	10 sec.	52
HDCP input	HDCP 2.2	53
Output		
Output mode	AUTO	54
Sink device EDID check	In case EDID cannot be read, DVI signal will be output	55
HDCP re-authentication	—	55
Audio		
Output mute	Mute OFF	56
Contact input		
Chattering reduction	30 ms.	57
EDID		
EDID resolution	2160p@60(3840x2160) 4:4:4	59
Frame rate	60Hz	63
Deep Color	24 bit/pixel (8 bit/component)	63
Audio format	PCM : 48 kHz Dolby Digital : OFF AAC : OFF Dolby Digital+ : OFF DTS : OFF DTS-HD : OFF Dolby TrueHD : OFF	64
Speaker configuration	MODE : AUTO NUMBER : 2ch (FL/FR)	65
Copying EDID	—	65

[Table 7.7] Factory default (2/2)

Setting	Factory default	See
RS-232C		
Baud rate	9600 bps	67
Data bit length	8 bit	67
Parity check	NONE	67
Stop bit	1 bit	67
LAN		
IP address	192.168.1.199	69
Subnet mask	255.255.255.0	69
MAC address	—	69
TCP port number	Connection 1 to 4: 1100 Connection 5 to 7: 23	69
Startup		
Start-up input channel	LAST CHANNEL	71
Button security lockout at startup	AUTO	71
Advanced settings		
Beep	ON	72
Device information	Firmware version	72
Status		
Input signal status	—	74
Sink device status	—	77
Displaying error message	—	78
Viewing sink device EDID	—	80

8 Configuration and Control

Descriptions in this chapter are based on the IMP-S41U.

8.1 WEB menu

You can set I/O, EDID, communication, and other settings from [MENU].

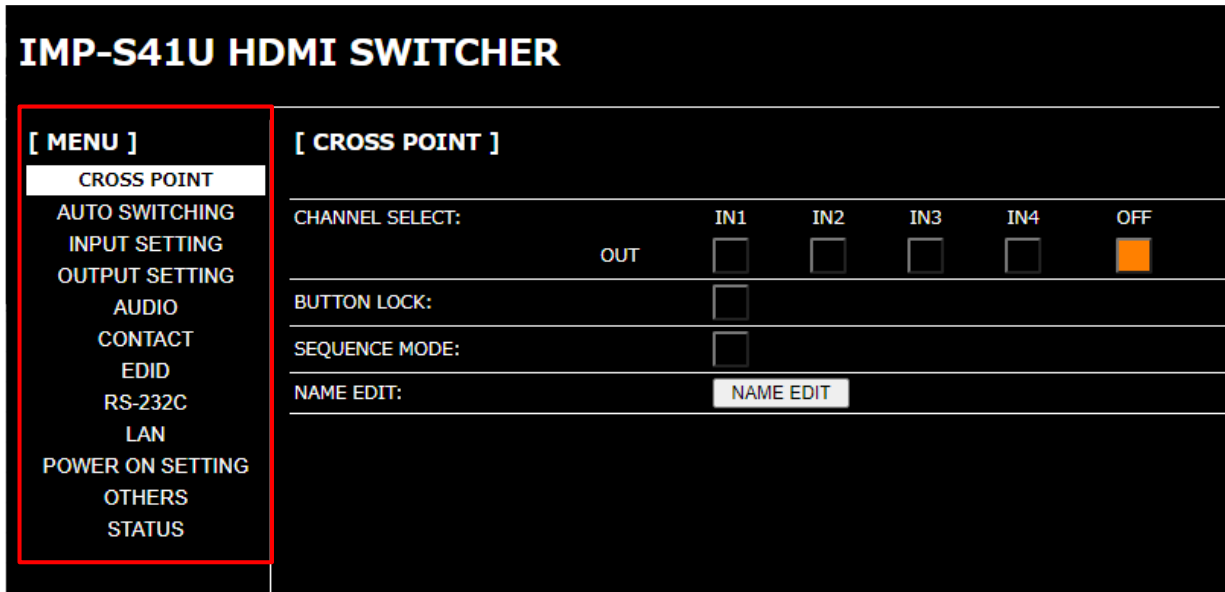

[Fig. 8.1] WEB menu (IMP-S41U)

[Table 8.1] WEB menu and setting

[MENU]	Description	Page
CROSS POINT	<ul style="list-style-type: none"> Selecting input channels Locking and Unlocking input selection buttons Setting sequence switching mode Editing I/O channels and device names 	31 to 34
AUTO SWITCHING	<ul style="list-style-type: none"> Automatic input channel switching Sequence switching mode 	43 to 50
INPUT SETTING	Input	51 to 53
OUTPUT SETTING	Output	54 to 55
AUDIO	Audio	56
CONTACT	Contact input	57 to 57
EDID	EDID	58 to 65
RS-232C	RS-232C	66 to 67
LAN	LAN	68 to 69
POWER ON SETTING	Startup	70 to 71
OTHERS	Advanced settings	72
STATUS	Status	73 to 81

8.2 Automatic input channel switching

You can set switching between automatic input channel mode and sequence switching mode from [AUTO SWITCHING].

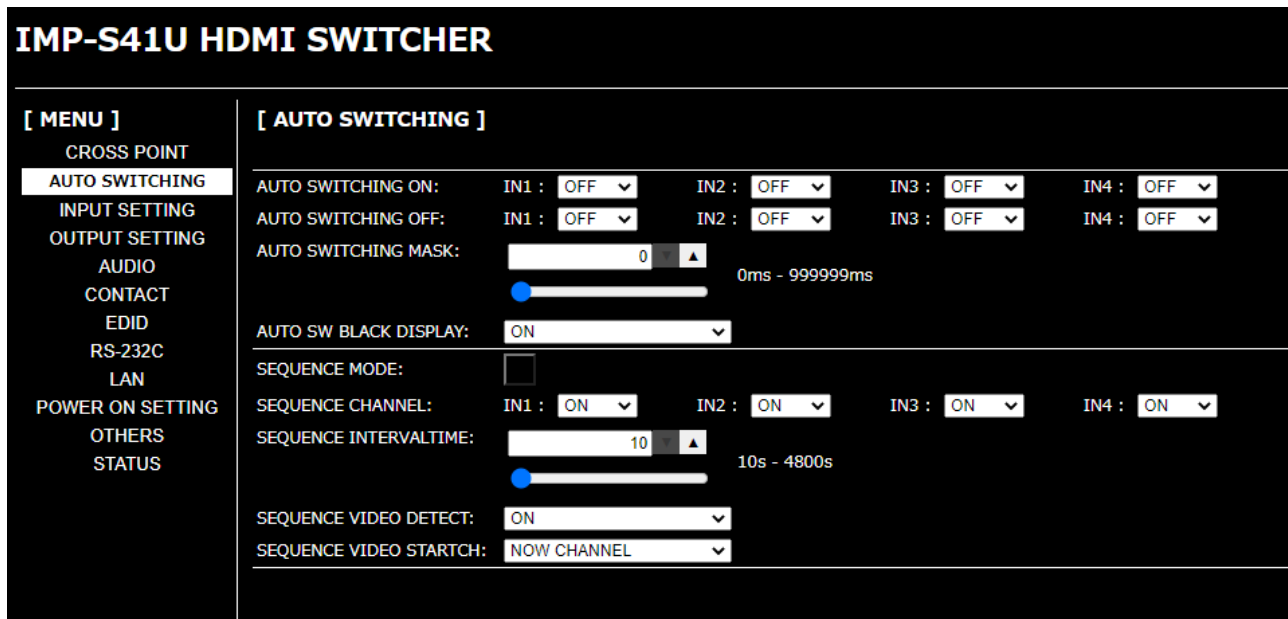

[Fig. 8.2] AUTO SWITCHING menu (IMP-S41U)

■ Automatic input channel switching

[Table 8.2] Submenu and feature

Submenu	Feature	Page
AUTO SWITCHING ON	Priority of input channel automatic switching	44
AUTO SWITCHING OFF		
AUTO SWITCHING MASK	Ignoring duration after automatic switching	47
AUTO SW BLACK DISPLAY	Video to be output when input channel is changed OFF to ON	47

■ Sequence switching mode

[Table 8.3] Sub menu and feature

Submenu	Feature	Page
SEQUENCE MODE	Sequence switching mode	48
SEQUENCE CHANNEL	Target channels for sequence switching mode	50
SEQUENCE INTERVALTIME	Switching interval of sequence switching mode	50
SEQUENCE VIDEO DETECT	Input detection	50
SEQUENCE VIDEO STARTCH	Start channel of sequence switching mode	50

8.2.1 Priority of input channel automatic switching

Menu	AUTO SWITCHING → AUTO SWITCHING ON (OFF to ON) AUTO SWITCHING → AUTO SWITCHING OFF (ON to OFF)
Setting value	OFF : Input switching priority OFF [Default] 1 to 4 : Input switching priority 1 (Highest) to 4 (Lowest)

The IMP-S switches input channel automatically when input signal is “OFF” to “ON” or “ON” to “OFF”. You can set the priority of automatic switching priority for each input channel.

■ From OFF to ON: [AUTO SWITCHING ON] submenu

The input channel will be switched automatically if the INPUT SIGNAL LED illuminates yellow, the input video signal is stable for 4 seconds, and in case of one of the following conditions. The input selection button flashes from when the input signal is detected to when the channel is switched automatically or no signal is detected.

- When the input signal become from “OFF” to “ON”, and that input channel has higher priority than current channel or the same priority level.
- When the input signal become from “OFF” to “ON”, and other input channels that have higher priority than the input signal do not have input signal.

If input channel is switched by using WEB menu, input selection button, contact input or communication commands, automatic switching cannot be executed for 20 seconds. If the priority setting of the input channel is “OFF”, input channel automatic switching is not executed.

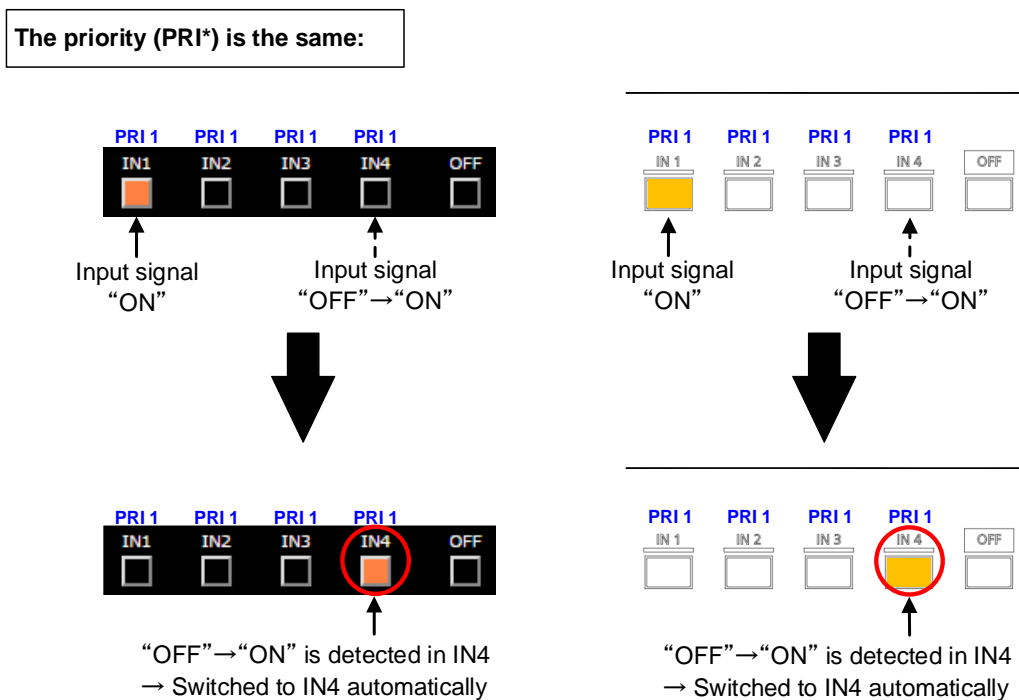

[Fig. 8.3] Input channel: “OFF” to “ON” (IMP-S41U, WEB browser and Front panel buttons)

The priority (PRI*) is not the same:

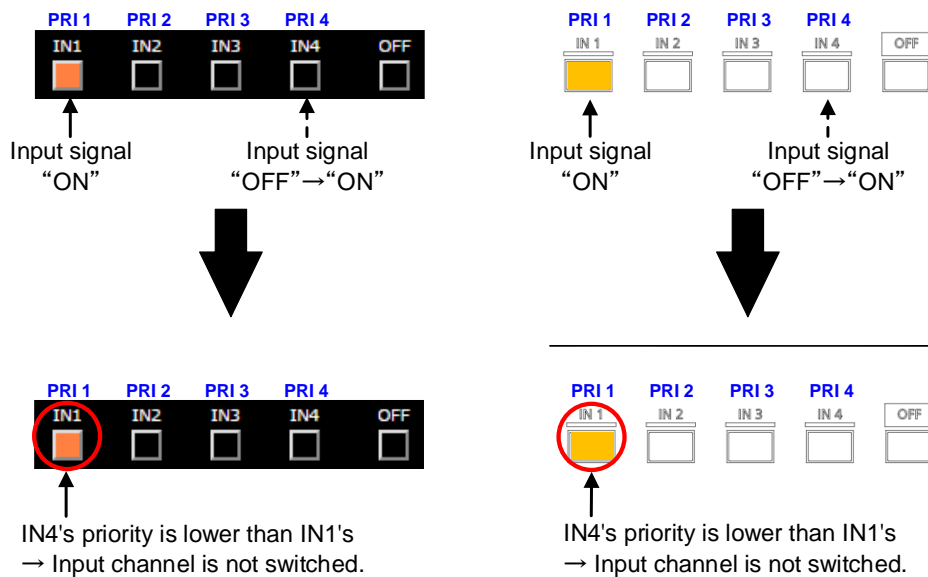

[Fig. 8.4] Input channel: "OFF" to "ON" (IMP-S41U, WEB browser and Front panel buttons)

■ From ON to OFF: [AUTO SWITCHING OFF] submenu

If the input signal changes from "ON" to "OFF" (the INPUT SIGNAL LED turns off) and no signal is input for three seconds, the input channel will be switched automatically as one of the following case. The input selection buttons flashes until the channel is switched automatically or no signal is detected.

- Input channel is switched to the channel that has the highest priority
- If some channels have the same priority, Input channel is switched to the lowest input channel

If input channel is switched by using WEB menu, input selection button, contact input or communication commands, automatic switching cannot be executed for 20 seconds. If the priority setting of the input channel is "OFF", input channel automatic switching is not executed.

The priority (PRI*) is the same:

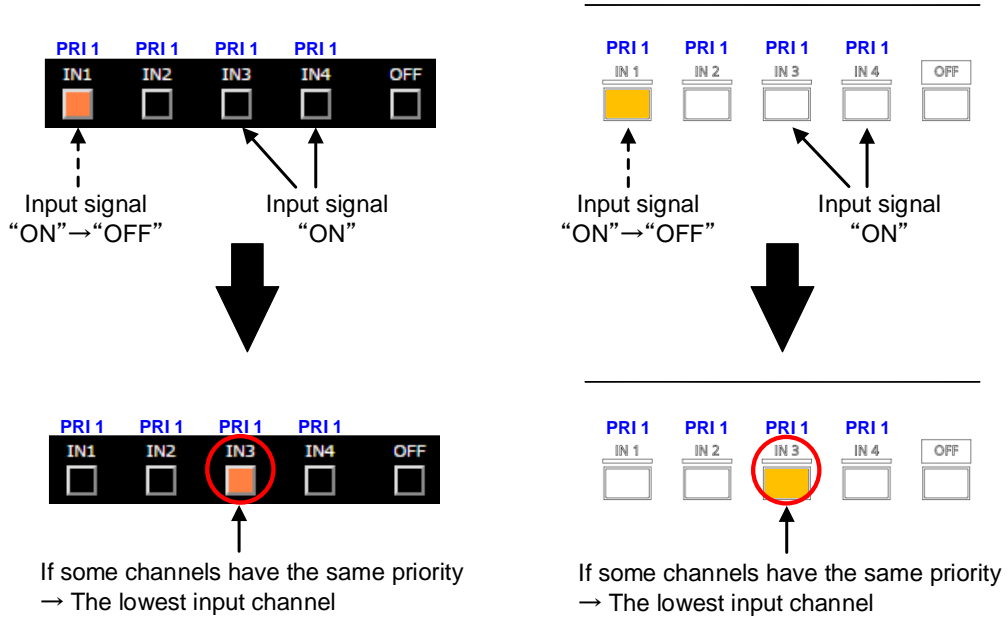

[Fig. 8.5] Input channel: “OFF” to “ON” (IMP-S41U, WEB browser and Front panel buttons)

The priority (PRI*) is not the same:

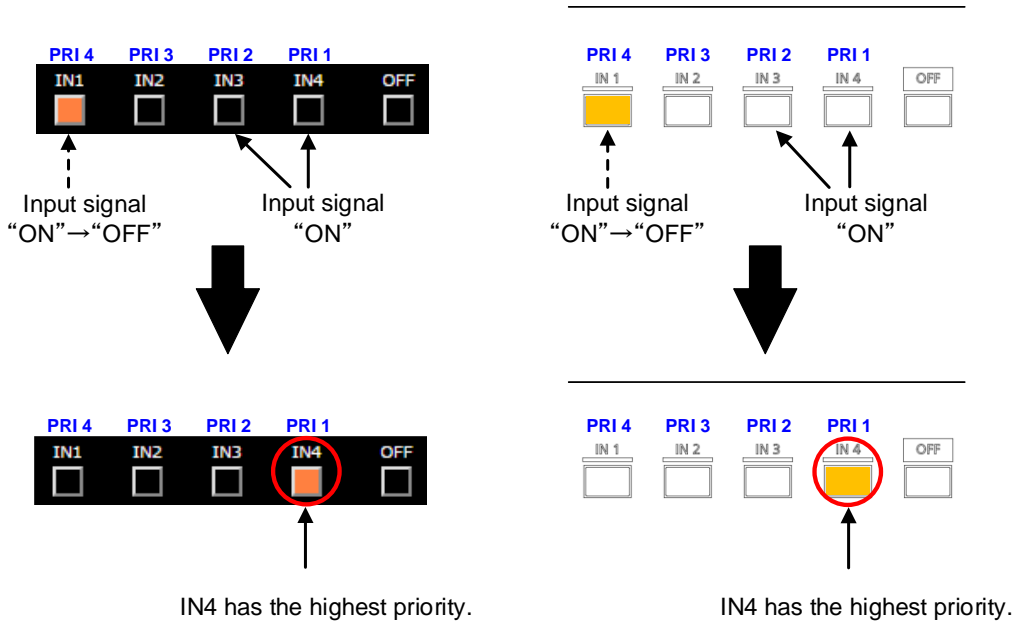

[Fig. 8.6] Input channel: “ON” to “OFF” (IMP-S41U, WEB browser and Front panel buttons)

8.2.2 Ignoring duration after automatic switching

Menu **AUTO SWITCHING** → **AUTO SWITCHING MASK**
Setting value 0 to 999999: 0 sec. to 999.999 sec. [Default] 0 sec.

You can set the time from when input channel is switched automatically until when the next automatic switching is performed. The automatic switching is not performed during the set time.

8.2.3 Video to be output when input channel is changed OFF to ON

Menu **AUTO SWITCHING** → **AUTO SW BLACK DISPLAY**
Setting value ON : Black is output. [Default]
OFF : Current video is output.

You can select black or current video that is output while video channel is being switched.

【See: 8.2.1 Priority of input channel automatic switching】

8.2.4 Sequence switching mode

Menu	AUTO SWITCHING → SEQUENCE MODE
Setting value	OFF : Disabled [Default] ON : Enabled Input channel can be switched automatically at the desired interval.

You can disable/enable sequence switching mode.

[Table 8.4] Switching for input channel switching

Setting	Default	Reference page	Remarks
Target channels	IN1 : ON IN2 : ON IN3 : ON IN4 : ON	8.2.5	If sequence switching mode is set to "ON", these settings cannot be set.
Interval	10 sec.	8.2.6	
In case no video signal is input, the input channel is skipped	ON	8.2.7	
Sequence mode starts from the current input channel or the lowest number channel Start channel of sequence switching mode <ul style="list-style-type: none"> ▪ NOW CHANNEL: Current input channel ▪ FIRST CHANNEL: Being set to be switched The lowest number channel 	NOW CHANNEL	8.2.8	

【See: 7.1.3 Setting sequence switching mode - IN2 button operation】

【See: 7.2.5 Setting sequence switching mode - WEB menu operation】

Tip:

If sequence switching mode is enabled, input channel is not switched even using input channel selection button.

IN1, IN3, and IN4 are targets to be switched
Interval: 10 seconds

Example1

Switching starts from: The current input channel (NOW CHANNEL)
 The current channel: IN3

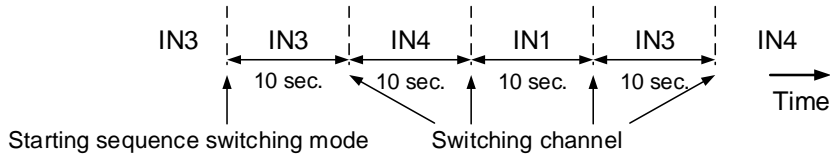

IN3 is included in the target channel → The sequence switching mode starts from IN3.

Example2

Switching starts from: The lowest number channel (FIRST CHANNEL)
 The current channel: IN3

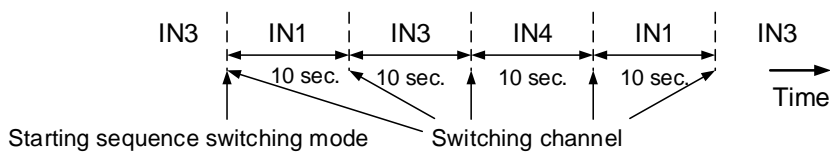

The lowest number channel is IN1 → The sequence switching mode starts from IN1.

Example3

Switching starts from: The current input channel (NOW CHANNEL)
 The current channel: IN2

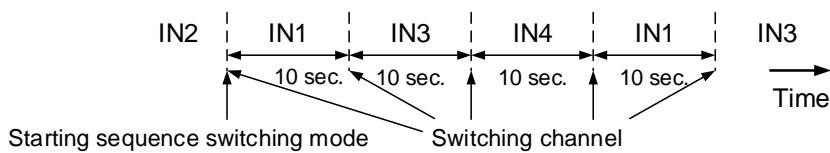

IN2 is not included in the target channel → The sequence switching mode starts from the lowest number channel (IN1).

Example4

Switching starts from: The current input channel (NOW CHANNEL)
 The current channel: IN3
 Video input signal detection [SEQUENCE VIDEO DETECT]: ON
 Channels having video input signal: IN1 and IN3

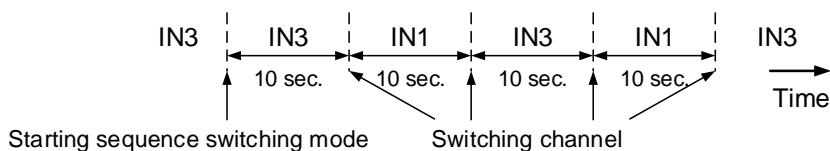

IN4 is skipped since it does not have video signal.

[Fig. 8.7] Examples of Sequence switching mode (IMP-S41U)

8.2.5 Target channels for sequence switching mode

Menu	AUTO SWITCHING → SEQUENCE CHANNEL
Setting value	ON : To be switched [Default] OFF : Not to be switched

You can set each input channel to be switched or not for when sequence switching mode is enabled.

Tip:

This setting cannot be changed if “8.2.4 Sequence switching mode” is set to “ON”.

8.2.6 Switching interval of sequence switching mode

Menu	AUTO SWITCHING → SEQUENCE INTERVALTIME
Setting value	10s to 4800s (by 1s): 10 sec. to 4800 sec. [Default] 10 sec.

You can set switching interval of sequence switching mode.

Tip:

This setting cannot be changed if “8.2.4 Sequence switching mode” is set to “ON”.

8.2.7 Input detection

Menu	AUTO SWITCHING → SEQUENCE VIDEO DETECT
Setting value	ON : Only input channels in which video signal is detected will be switched. [Default] OFF : All input channels are switched.

Only input channels in which video signal is detected will be switched.

Tip:

This setting cannot be changed if “8.2.4 Sequence switching mode” is set to “ON”.

8.2.8 Start channel of sequence switching mode

Menu	AUTO SWITCHING → SEQUENCE VIDEO STARTCH
Setting value	NOW CHANNEL : Starts with the current input channel. [Default] FIRST CHANNEL : Starts with the lowest number channel of target channels.

The sequence switching mode starts with the set channel. See “8.2.4 Sequence switching mode” for details.

Tip:

This setting cannot be changed if “8.2.4 Sequence switching mode” is set to “ON”.

8.3 Input

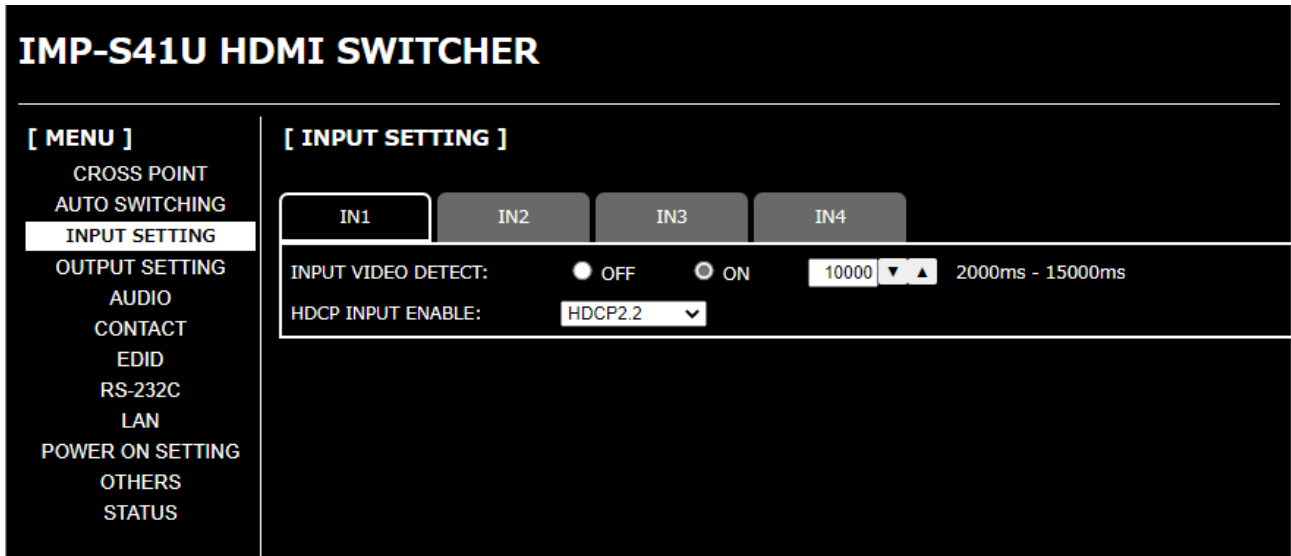

[Fig. 8.8] INPUT SETTING menu (IMP-S41U)

[Table 8.5] Submenu and feature

Submenu	Feature	Page
INPUT VIDEO DETECT	No-signal input monitoring	52
HDCP INPUT ENABLE	HDCP input	53

8.3.1 No-signal input monitoring

Menu	INPUT SETTING → INPUT VIDEO DETECT
Setting value	OFF : Not monitoring ON : Monitoring 2000 to 15000 (by 100 ms.): 2 sec. to 15 sec. [Default] 10 sec.

If you change the EDID settings of the IMP-S or power the IMP-S off/on, the source device may not output a video signal. Use this menu to set the monitoring time. This is the interval beginning when a source device is not outputting a signal; and ending at the point when the IMP-S requests an output from that source device.

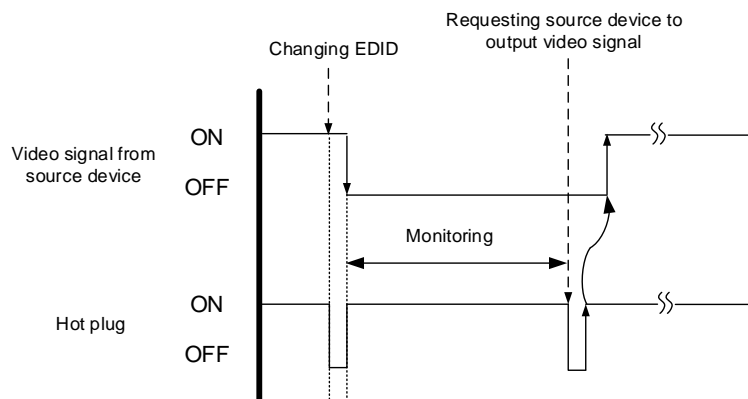

[Fig. 8.9] Monitoring absence of input

If you are using the monitor power-saving or dual monitor features on your PC, set this feature to “OFF”. This will avoid potentially unpredictable operation.

When using this feature, ensure that the “monitoring time” is set for a value greater than the amount of time needed for the source to provide an output signal.

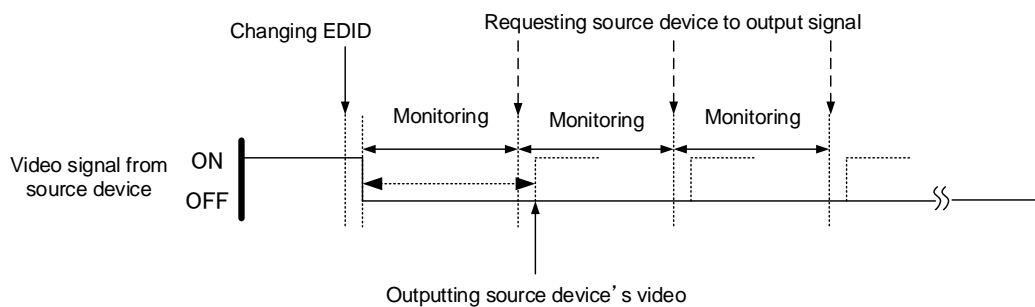

[Fig. 8.10] Repeating output reset

8.3.2 HDCP input

Menu	INPUT SETTING → HDCP INPUT ENABLE
Setting value	HDCP2.2: Supports HDCP 2.2 and HDCP 1.4 [Default] HDCP1.4: Supports HDCP 1.4 DISABLE: Not support HDCP

Some source devices negotiate with the connected device to determine if HDCP encryption is supported. After this negotiation, the source device determines whether HDCP signal encryption is enforced or not. This process takes place with some source device, even if the content being presented is not copyright protected. The IMP-S is HDCP compliant, if it is connected to a display device that does not support HDCP, even unprotected AV content may not be successfully displayed. Under these circumstances and if the content is indeed not protected, the problem can be solved by setting this menu to “DISABLE.”

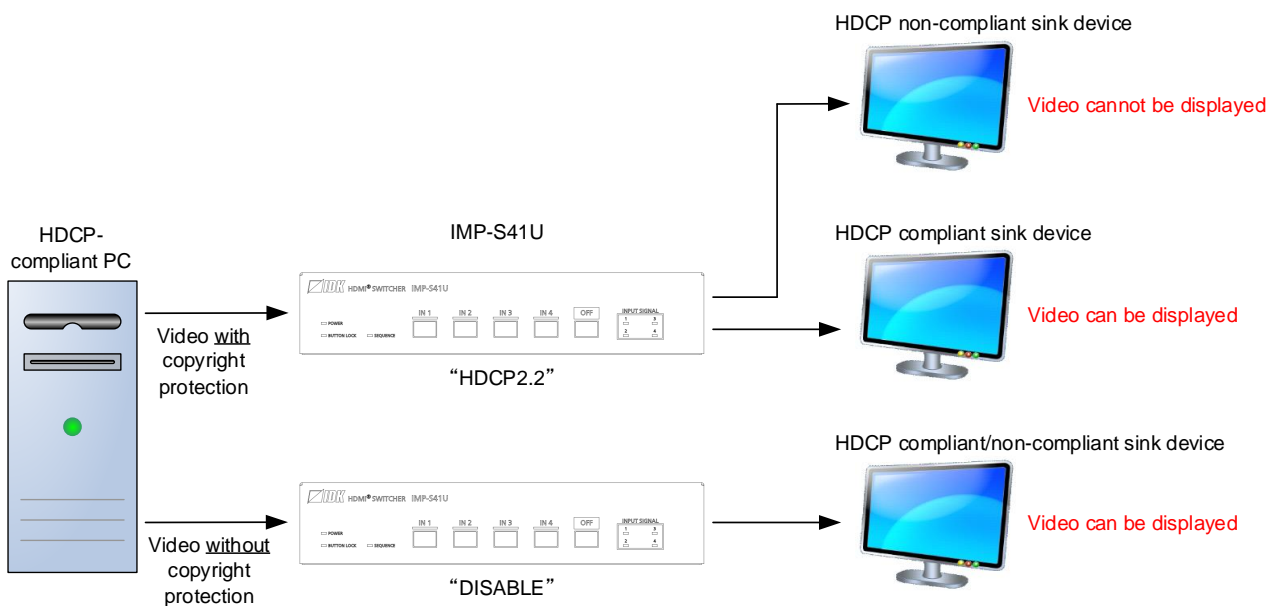

[Fig. 8.11] HDCP-compliant and HDCP non-compliant sink device (IMP-S41U)

Note:

Set this setting to HDCP2.2 or HDCP1.4 in order to display video with copyright protection.

- HDCP2.2 (stream type 0) contents can be displayed on sink devices supporting HDCP1.4.
- HDCP2.2 (stream type 1) contents can be displayed on sink devices supporting HDCP2.2 but cannot be displayed on sink devices supporting HDCP1.4.

8.4 Output

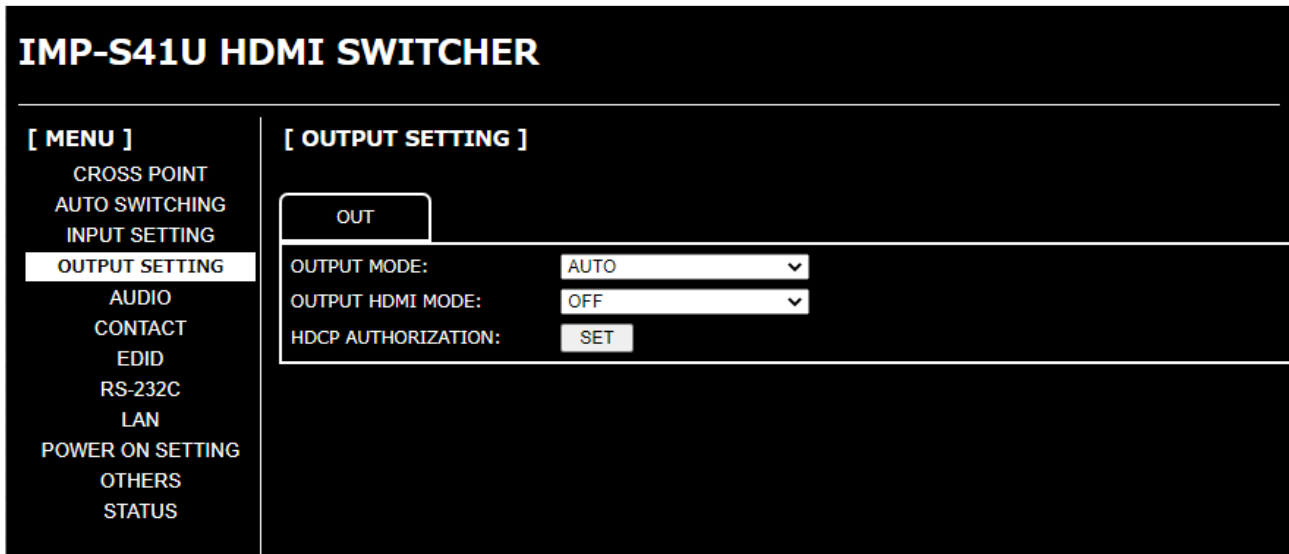

[Fig. 8.12] OUTPUT SETTING menu (IMP-S41U)

[Table 8.6] Submenu and feature

Submenu	Feature	Page
OUTPUT MODE	Output mode	54
OUTPUT HDMI MODE	Sink device EDID check	55
HDCP AUTHORIZATION	HDCP re-authentication	55

8.4.1 Output mode

Menu	OUTPUT SETTING → OUTPUT MODE
Setting value	AUTO : Automatic [Default] DVI MODE : DVI output HDMI RGB MODE : RGB output HDMI YCbCr4:2:0 MODE: YCbCr 4:2:0 output HDMI YCbCr4:2:2 MODE: YCbCr 4:2:2 output HDMI YCbCr4:4:4 MODE: YCbCr 4:4:4 output

You can select an output signal mode and color space of the output video.
The selected mode has priority and is output to the sink device with the optimal mode.

Notes:

- When 4K YCbCr 4:4:4 signal is input, the IMP-S outputs the signal at YCbCr 4:2:0 to the sink device supporting YCbCr 4:2:0 (not supporting YCbCr 4:4:4).
- For 4K YCbCr 4:2:0, only CEA-861 Video Format Timings are supported.
- If DVI MODE is selected and input signal is transmitted at 4K@30 or less, it will be DVI output.
- For DVI MODE, digital audio is not output.

8.4.2 Sink device EDID check

Menu	OUTPUT SETTING → OUTPUT HDMI MODE
Setting value	OFF : In case of EDID load error, the sink device is treated as a DVI device [Default] ERROR1 : In case of EDID load error, the sink device is treated as a HDMI device without SCDC ALWAYS1 : Always treats sink device as a HDMI device without SCDC ERROR2 : In case of EDID load error, the sink device is treated as a HDMI device with SCDC ALWAYS2 : Always treats sink device as a HDMI device with SCDC

The IMP-S gets EDID from the sink device and determines if the sink device is an HDMI device or DVI device in order to output HDMI signals. However, if the IMP-S cannot get EDID for some reasons, problems such as no audio output and the like may occur. In these cases, IMP-S recognized the connected sink device is HDMI or DVI device and output signal as HDMI or DVI mode depending on its setting.

Notes:

- If setting this menu to other than the default, set “**8.7.1 EDID resolution**” to the appropriate resolution other than EXTERNAL EDID.
- This setting is applied when HDMI signal is input and “**8.4.1 Output mode**” is set to a format other than DVI.

【See: 8.4.1 Output mode】

8.4.3 HDCP re-authentication

Menu	OUTPUT SETTING → HDCP AUTHORIZATION
------	-------------------------------------

If an HDCP-compliant device is connected, HDCP is authorized automatically. You can re-authorize HDCP manually at the desired timing using this menu.

8.5 Audio



[Fig. 8.13] AUDIO menu (IMP-S41U)

[Table 8.7] Submenu and feature

Submenu	Feature	Page
OUTPUT MUTE	Output mute	56

8.5.1 Output mute

Menu **AUDIO** → **OUTPUT MUTE**

Setting value **ON** : Mute ON
OFF : Mute OFF [Default]

You can mute/unmute the output audio.

8.6 Contact input

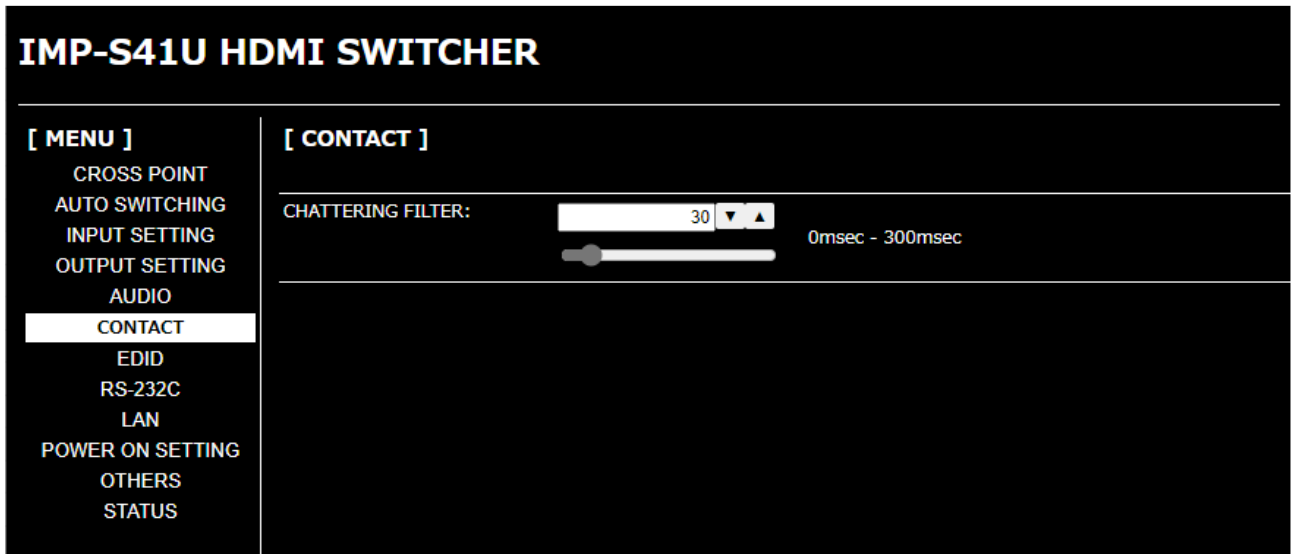

[Fig. 8.14] CONTACT menu (IMP-S41U)

[Table 8.8] Submenu and feature

Submenu	Feature	Page
CHATTERING FILTER	Chattering reduction	57

8.6.1 Chattering reduction

Menu CONTACT → CHATTERING FILTER
 Setting value 0 to 300: 0 ms. to 300 ms. [Default] 30 ms.

Chattering is an undesirable phenomenon caused immediately after contact of relay or switch is switched. You can set the chattering reduction time. If the IMP-S is unstable due to chattering, set the reduction time longer.

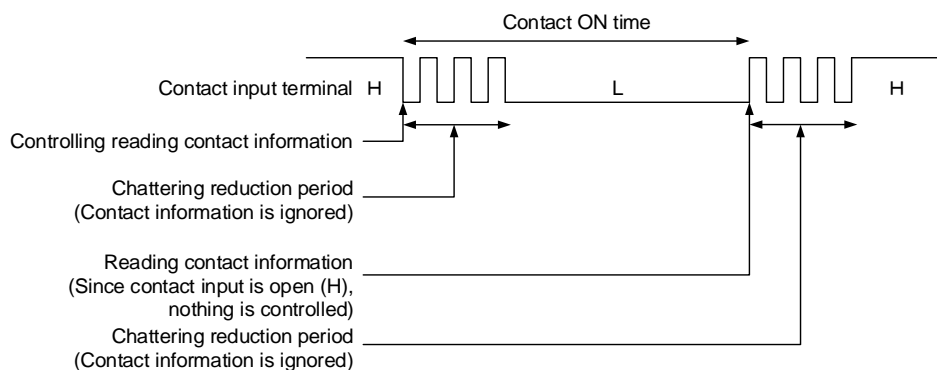

[Fig. 8.15] Chattering reduction

8.7 EDID

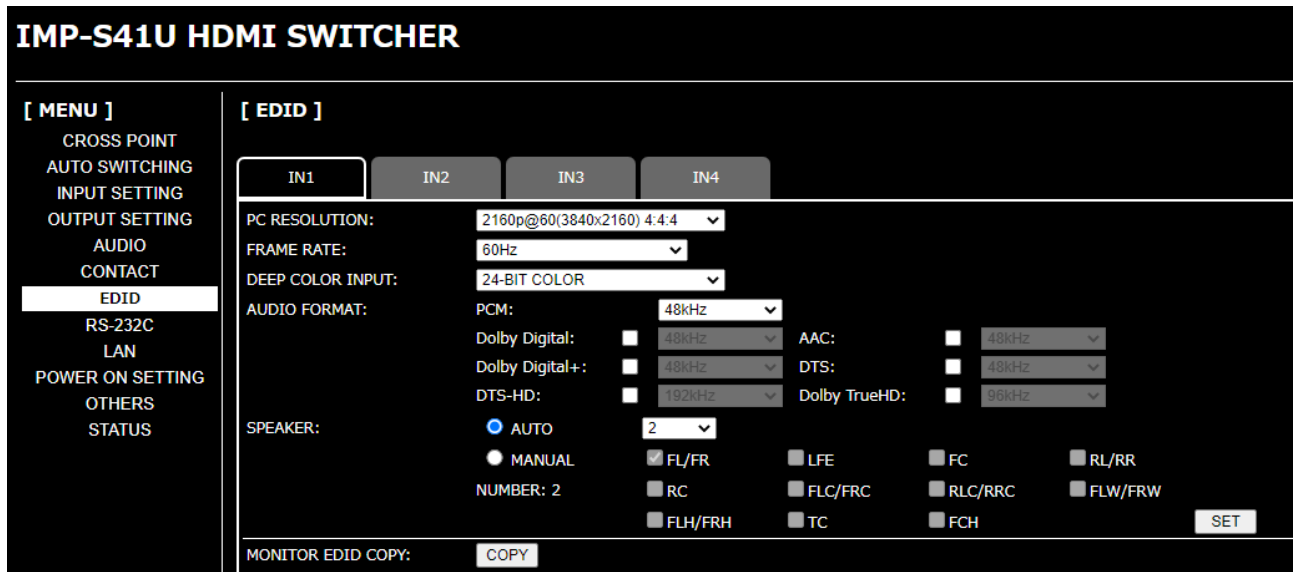

[Fig. 8.16] EDID menu (IMP-S41U)

[Table 8.9] Submenu and feature

Submenu	Feature	Page
PC RESOLUTION	EDID resolution	59
FRAME RATE	Frame rate	63
DEEP COLOR INPUT	Deep Color	63
AUDIO FORMAT	Audio format	64
SPEAKER	Speaker configuration	65
MONITOR EDID COPY	Copying EDID	65

8.7.1 EDID resolution

Menu	EDID → PC RESOLUTION
Setting value	[Table 8.10] Maximum resolution of EDID

You can set the EDID to be sent to the source device.

This setting will also be applied for controlling output resolution when AV devices (such as Blu-ray players) are connected via HDMI.

“SVGA(800x600)” to “4096x2160@60 4:4:4” are the built-in EDID of the IMP-S. If using the internal EDID, specify the maximum supported resolution.

Timing of 720p, 1080i, 1080p, 2160p, and 4096x2160 is the same as that of HD signal meeting the CEA-861 standard.

For other resolutions, timing parameters meet the VESA DMT or VESA CVT standards.

HDR is supported if external EDID is selected for EDID setting while an HDR-supported sink device is connected or if copied EDID of an HDR-supported sink device is selected for EDID setting.

3D is supported if external EDID is selected for EDID setting while a 3D-supported sink device is connected or if copied EDID of 3D-supported sink device is selected for EDID setting.

[Table 8.10] Maximum resolution of EDID

Setting value	Maximum resolution Pixels	Standard	Remarks
EXTERNAL	EXTERNAL (External EDID) —	—	If no sink device is connected, EDID of the sink device that was connected before “EXTERNAL” is selected.
COPY EDID	Copied EDID —	—	If no data is acquired, previous setting (immediately before selecting copied EDID) is kept.
SVGA(800x600)	SVGA 800x600	VESA	—
XGA(1024x768)	XGA 1024x768		—
VESA720(1280x720)	VESA720 1280x720		For DVI device input
720p(1280x720)	720p 1280x720	HDTV	—
WXGA(1280x768)	WXGA 1280x768	VESA	—
WXGA(1280x800)	WXGA 1280x800		—
QuadVGA(1280x960)	QuadVGA 1280x960		—
SXGA(1280x1024)	SXGA 1280x1024		—
WXGA(1360x768)	WXGA 1360x768		—

[Table 8.11] Maximum resolution of EDID (Cont'd)

Setting value	Maximum resolution Pixels	Standard	Remarks
WXGA(1366x768)	WXGA 1366x768	VESA	—
SXGA+(1400x1050)	SXGA+ 1400x1050		—
WXGA+(1440x900)	WXGA+ 1440x900		—
WXGA++(1600x900)	WXGA++ 1600x900		(RB)
UXGA(1600x1200)	UXGA 1600x1200		—
WSXGA+(1680x1050)	WSXGA+ 1680x1050		—
1080i(1920x1080)	1080i 1920x1080	HDTV	—
1080p@30(1920x1080)	1080p (24/25/30) 1920x1080		—
VESA1080(1920x1080)	VESA1080 1920x1080	VESA	(RB), For DVI device input
1080p@60(1920x1080)	1080p (50/59.94/60) 1920x1080	HDTV	—
WUXGA(1920x1200)	WUXGA 1920x1200	VESA	(RB)
QWXGA(2048x1152)	QWXGA 2048x1152		(RB)
WQHD(2560x1440)	WQHD 2560x1440		(RB)
WQXGA(2560x1600)	WQXGA 2560x1600		(RB)
2160p@30(3840x2160)	2160p (24/25/30) 3840x2160	UHDTV	—
4096x2160@30	4096x2160 (24/25/30) 4096x2160	DCI	—
2160p@60(3840x2160) 4:2:0	2160p (50/59.94/60, 4:2:0) 3840x2160	UHDTV	YCbCr 4:2:0 supported
4096x2160@60 4:2:0	4096x2160 (50/59.94/60, 4:2:0) 4096x2160	DCI	YCbCr 4:2:0 supported
2160p@60(3840x2160) 4:4:4	2160p (50/59.94/60, 4:4:4) 3840x2160	UHDTV	YCbCr 4:2:0, YCbCr 4:2:2, YCbCr 4:4:4 supported [Default]
4096x2160@60 4:4:4	4096x2160 (50/59.94/60, 4:4:4) 4096x2160	DCI	YCbCr 4:2:0, YCbCr 4:2:2, YCbCr 4:4:4 supported

(RB): Reduced Blanking

Notes:

- For 4096x2160
The source device may select 3840x2160 (30p, YCbCr 4:4:4) depending on the EDID definition.
First set built-in EDID and then select 4096x2160 in the source device side.

- For YCbCr4:2:0
The source device may select 3840x2160 (30p, YCbCr 4:4:4) depending on the EDID definition. First set built-in EDID and then select YCbCr 4:2:0 in the source device side.

- For source devices that do not support 4K:
The built-in EDID's default value is 4K UHD TV (up to 2160p@60 (3840x2160) 4:4:4). If a source device that does not support 4K, video may not be output or audio may not be output. Change the EDID setting to the correct resolution in order to output HDMI signal from the source device.

[Table 8.12] Supported resolution

Supported resolution / Input resolution setting	Supported resolution																												
	640x480	800x600	1024x768	VESA720	720p	1280x768	1280x800	1280x960	1280x1024	1360x768	1366x768	1400x1050	1440x900	1600x900	1600x1200	1680x1050	1080i	1080p (24/25/30)	VESA1080	1080p (50/59.94/60)	1920x1200	2048x1152	2560x1440	2560x1600	3840x2160 (30p)	4096x2160 (30p)	3840x2160 (60p)	4096x2160 (60p)	
—	—	—	—	—	—	—	—	—	—	—	—	—	—	—	—	—	—	—	—	—	—	—	—	—	—	—	—	—	—
800x600	Y	Y	N	N	N	N	N	N	N	N	N	N	N	N	N	N	N	N	N	N	N	N	N	N	N	N	N	N	N
1024x768	Y	Y	Y	N	N	N	N	N	N	N	N	N	N	N	N	N	N	N	N	N	N	N	N	N	N	N	N	N	N
VESA720	Y	Y	Y	Y	N	N	N	N	N	N	N	N	N	N	N	N	N	N	N	N	N	N	N	N	N	N	N	N	N
720p	Y	Y	Y	N	Y	N	N	N	N	N	N	N	N	N	N	N	N	N	N	N	N	N	N	N	N	N	N	N	N
1280x768	Y	Y	Y	N	Y	Y	N	N	N	N	N	N	N	N	N	N	N	N	N	N	N	N	N	N	N	N	N	N	N
1280x800	Y	Y	Y	N	Y	Y	Y	N	N	N	N	N	N	N	N	N	N	N	N	N	N	N	N	N	N	N	N	N	N
1280x960	Y	Y	Y	N	Y	Y	Y	Y	N	N	N	N	N	N	N	N	N	N	N	N	N	N	N	N	N	N	N	N	N
1280x1024	Y	Y	Y	N	Y	Y	Y	Y	Y	N	N	N	N	N	N	N	N	N	N	N	N	N	N	N	N	N	N	N	N
1360x768	Y	Y	Y	N	Y	Y	Y	Y	Y	Y	N	Y	Y	N	N	N	N	N	N	N	N	N	N	N	N	N	N	N	N
1366x768	Y	Y	Y	N	Y	Y	Y	Y	Y	N	Y	N	N	N	N	N	N	N	N	N	N	N	N	N	N	N	N	N	N
1400x1050	Y	Y	Y	N	Y	N	Y	Y	Y	N	Y	Y	N	N	N	N	N	N	N	N	N	N	N	N	N	N	N	N	N
1440x900	Y	Y	Y	N	Y	N	Y	Y	Y	N	Y	Y	Y	N	N	N	N	N	N	N	N	N	N	N	N	N	N	N	N
1600x900	Y	Y	Y	N	Y	N	Y	Y	Y	N	Y	Y	Y	Y	N	N	N	N	N	N	N	N	N	N	N	N	N	N	N
1600x1200	Y	Y	Y	N	Y	N	Y	Y	Y	N	Y	Y	Y	Y	N	N	N	N	N	N	N	N	N	N	N	N	N	N	N
1680x1050	Y	Y	Y	N	Y	N	Y	Y	Y	N	Y	Y	Y	Y	Y	N	N	N	N	N	N	N	N	N	N	N	N	N	N
1080i	Y	Y	Y	N	Y	N	N	N	N	N	N	N	N	N	N	N	Y	N	N	N	N	N	N	N	N	N	N	N	N
1080p (24/25/30)	Y	Y	Y	N	Y	N	N	N	N	N	N	N	N	N	N	N	N	Y	N	N	N	N	N	N	N	N	N	N	N
VESA1080	Y	Y	Y	N	Y	N	N	Y	Y	N	Y	Y	Y	Y	Y	Y	N	Y	N	N	N	N	N	N	N	N	N	N	N
1080p (50/59.94/60)	Y	Y	Y	N	Y	N	N	Y	Y	N	Y	Y	Y	Y	Y	Y	N	N	Y	N	N	N	N	N	N	N	N	N	N
1920x1200	Y	Y	Y	N	Y	N	N	Y	Y	N	N	Y	Y	Y	Y	Y	N	N	Y	Y		N	N	N	N	N	N	N	N
2048x1152	Y	Y	Y	N	Y	N	N	Y	Y	N	N	Y	Y	Y	Y	Y	N	N	Y	Y	Y	N	N	N	N	N	N	N	N
2560x1440	Y	Y	Y	N	Y	N	N	Y	Y	N	N	Y	Y	Y	Y	Y	N	N	Y	N	Y	Y	Y	N	N	N	N	N	N
2560x1600	Y	Y	Y	N	Y	N	N	N	Y	N	N	Y	Y	Y	Y	Y	N	N	Y	N	Y	Y	Y	Y	N	N	N	N	N
2160p (24/25/30)	Y	Y	Y	N	Y	N	N	N	Y	N	N	Y	Y	Y	Y	Y	N	N	Y	N	Y	N	Y	N	Y	Y	N	N	N
4096x2160 (24/25/30)	Y	Y	Y	N	Y	N	N	N	Y	N	N	Y	Y	Y	Y	Y	N	N	Y	N	Y	N	Y	N	Y	Y	Y	N	N
2160p (50/59.94/60, 4:2:0)	Y	Y	Y	N	Y	N	N	N	Y	N	N	Y	Y	Y	Y	Y	N	N	Y	N	Y	N	Y	N	Y	Y	N	P	N
4096x2160 (50/59.94/60, 4:2:0)	Y	Y	Y	N	Y	N	N	N	Y	N	N	Y	Y	Y	Y	Y	N	N	Y	N	Y	N	Y	N	Y	Y	Y	P	P
2160p (50/59.94/60, 4:4:4)	Y	Y	Y	N	Y	N	N	N	Y	N	N	Y	Y	Y	Y	Y	N	N	Y	N	Y	N	Y	N	Y	N	Y	N	N
4096x2160 (50/59.94/60, 4:4:4)	Y	Y	Y	N	Y	N	N	N	Y	N	N	Y	Y	Y	Y	Y	N	N	Y	N	Y	N	Y	N	Y	Y	Y	Y	Y

Y: Supported, P: Only YCbCr 4:2:0, N: Not supported, —: Not used

8.7.2 Frame rate

Menu	EDID → FRAME RATE
Setting value	60Hz [Default] 50Hz

You can set the vertical sync frequency that is output from the source device.

This setting is enabled if a resolution other than “EXTERNAL” or “Copied EDID” is selected in “**8.7.1 EDID resolution**”.

8.7.3 Deep Color

Menu	EDID → DEEP COLOR INPUT
Setting value	24-BIT COLOR : 24 bit/pixel (8 bit/component) [Default] 30-BIT COLOR : 30 bit/pixel (10 bit/component) 36-BIT COLOR : 36 bit/pixel (12 bit/component)

You can set the Deep Color (Color depth) that is output from the source device.

This setting is enabled if a resolution other than “EXTERNAL” or “Copied EDID” is selected in “**8.7.1 EDID resolution**”.

Notes:

- If you select “30 bit/pixel (10 bit/component)” or “36 bit/pixel (12 bit/component)”, the video signal is transmitted using a higher clock frequency, which may cause noise if a cable with a bad quality or a long cable is connected. In such a case, the noise may be removed by setting the color to “24 bit/pixel (8 bit/component)”
- For 4K format vertical synchronous frequency at 50/59.94/60 Hz (YCbCr 4: 4: 4), “24 bit/pixel (8 bit/component)” is selected automatically regardless of the setting of this menu.

8.7.4 Audio format

Menu EDID → AUDIO FORMAT

Setting value [Table 8.13] Audio format

You can set the audio format and maximum sampling frequency to be output from a source device. This menu is enabled if you select a resolution other than “EXTERNAL” or “Copied EDID” in “**8.7.1 EDID resolution**”.

[Table 8.13] Audio format

Audio format	Maximum sampling frequency (kHz)	Default
PCM	32/44.1/48/88.2/96/176.4/192	48
Dolby Digital	OFF/32/44.1/48	OFF
AAC	OFF/32/44.1/48/88.2/96	OFF
Dolby Digital+	OFF/32/44.1/48	OFF
DTS	OFF/32/44.1/48/96	OFF
DTS-HD	OFF/44.1/48/88.2/96/176.4/192	OFF
Dolby TrueHD	OFF/44.1/48/88.2/96/176.4/192	OFF

Notes:

- LC monitors do not support some audio formats. Select an audio format and sampling frequency supported by the device.
- If compressed audio (Dolby Digital and DTS) is input, analog audio is not output. You can check the input audio type in “**8.12.1 Input signal status**”.

8.7.5 Speaker configuration

Menu EDID → SPEAKER

Setting value [Table 8.14] Default speaker configuration

You can set the speaker configuration of multi-channel audio.

When the number of speakers is changed, the speaker configuration is set to the value shown in “[Table 8.14] Default speaker configuration” automatically.

When changing the default configuration, you can set desired speaker individually.

This menu is enabled if you select a resolution other than “EXTERNAL” or “Copied EDID” in “8.7.1 EDID resolution”.

[Table 8.14] Default speaker configuration

The number of speakers	FL/FR	LFE	FC	RL/RR	RC	FLC/FRC	RLC/RRC	FLW/FRW	FLH/FRH	TC	FCH
1	OFF	OFF	ON	OFF	OFF	OFF	OFF	OFF	OFF	OFF	OFF
2 [Default]	ON	OFF	OFF	OFF	OFF	OFF	OFF	OFF	OFF	OFF	OFF
3	ON	ON	OFF	OFF	OFF	OFF	OFF	OFF	OFF	OFF	OFF
4	ON	ON	ON	OFF	OFF	OFF	OFF	OFF	OFF	OFF	OFF
5	ON	ON	OFF	ON	OFF	OFF	OFF	OFF	OFF	OFF	OFF
6	ON	ON	ON	ON	OFF	OFF	OFF	OFF	OFF	OFF	OFF
7	ON	ON	ON	ON	ON	OFF	OFF	OFF	OFF	OFF	OFF
8	ON	ON	ON	ON	OFF	OFF	ON	OFF	OFF	OFF	OFF

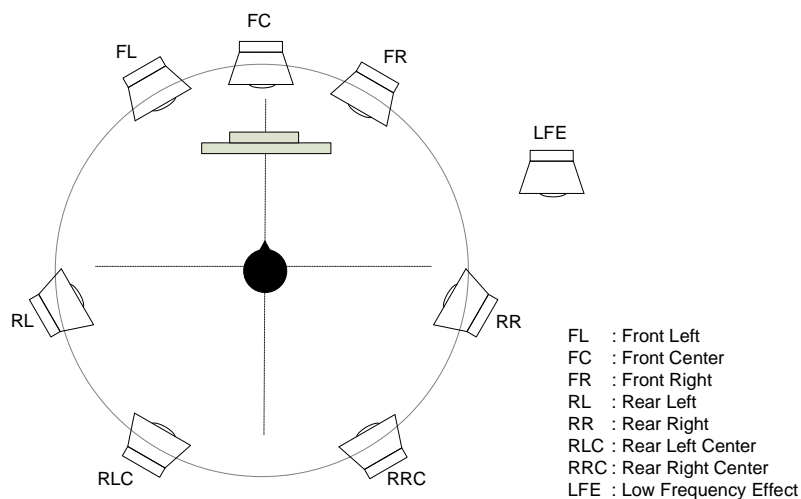

[Fig. 8.17] Speaker configuration

8.7.6 Copying EDID

Menu EDID → MONITOR EDID COPY

EDID of the sink device is loaded and registered to the IMP-S.

The EDID can be treated as a built-in EDID.

8.8 RS-232C

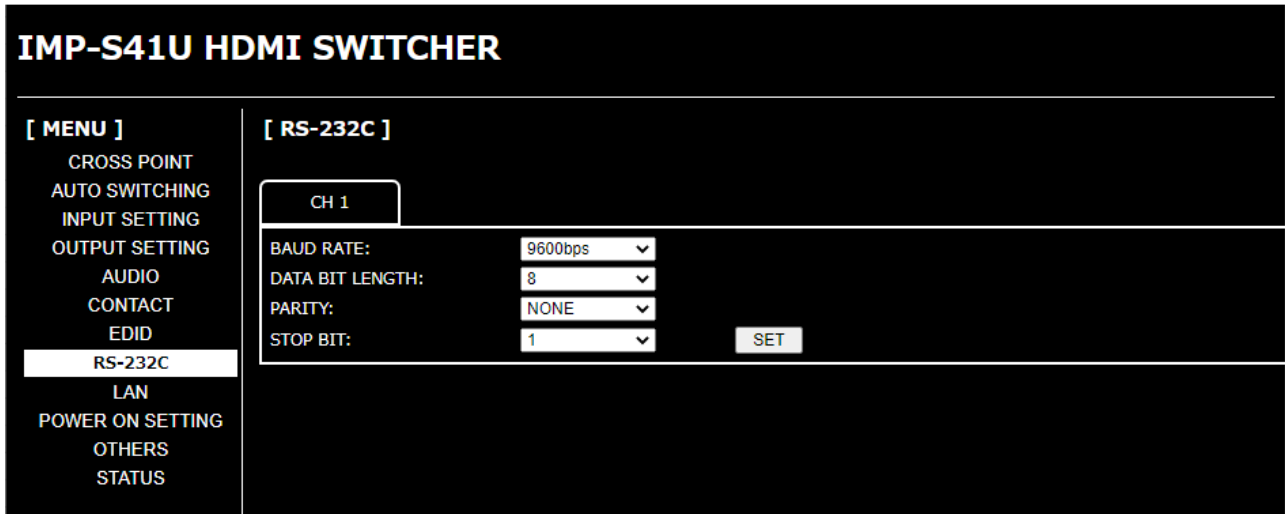

[Fig. 8.18] RS-232C menu (IMP-S41U)

[Table 8.15] Submenu and feature

Submenu	Feature	Page
BAUD RATE	Baud rate	67
DATA BIT LENGTH	Data bit length	67
PARITY	Parity check	67
STOP BIT	Stop bit	67

8.8.1 Baud rate

Menu	RS-232C → BAUD RATE
Setting value	4800bps : 4800 bps 9600bps : 9600 bps [Default] 19200bps: 19200 bps 38400bps: 38400 bps

8.8.2 Data bit length

Menu	RS-232C → DATA BIT LENGTH
Setting value	8 : 8 bit [Default] 7 : 7 bit

8.8.3 Parity check

Menu	RS-232C → PARITY
Setting value	NONE [Default] EVEN ODD

8.8.4 Stop bit

Menu	RS-232C → STOP BIT
Setting value	1 : 1 bit [Default] 2 : 2 bit

8.9 LAN

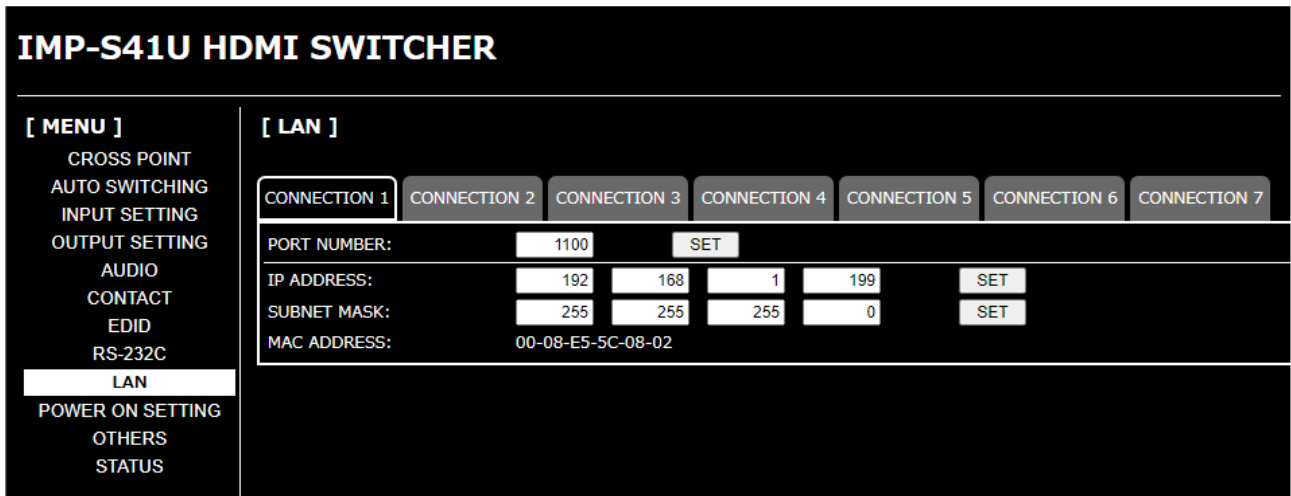

[Fig. 8.19] LAN menu (IMP-S41U)

[Table 8.16] Submenu and feature

Submenu	Feature	Page
IP ADDRESS	IP address	69
SUBNET MASK	Subnet mask	69
MAC ADDRESS	MAC address	69
PORT NUMBER	TCP port number	69

8.9.1 IP address

Menu LAN → IP ADDRESS
 Setting value 192.168.1.199 [Default]

8.9.2 Subnet mask

Menu LAN → SUBNET MASK
 Setting value 255.255.255.0 [Default]

8.9.3 MAC address

Menu LAN → MAC ADDRESS

8.9.4 TCP port number

Menu LAN → PORT NUMBER
 Setting value [Table 8.17] TCP port number

[Table 8.17] TCP port number

For	Setting value
Communication command control	23, 1100, 6000 to 6999
WEB browser control	80, 5000 to 5999

[Default]Connection 1 to 4: 1100, Connection 5 to 7: 23, Connection 8: 80 (fixed)

8.10 Startup

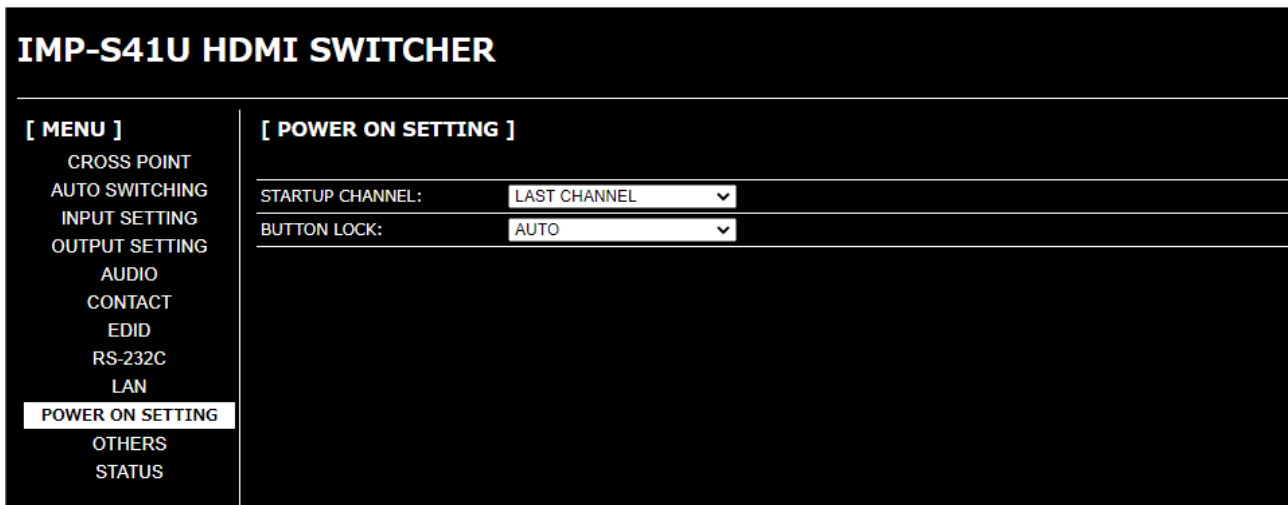

[Fig. 8.20] POWER ON SETTING menu (IMP-S41U)

[Table 8.18] Submenu and feature

Submenu	Feature	Page
STARTUP CHANNEL	Start-up input channel	71
BUTTON LOCK	Button security lockout at startup	71

8.10.1 Start-up input channel

Menu	POWER ON SETTING → STARTUP CHANNEL
Setting value	IN1 to IN4 OFF LAST CHANNEL [Default]

You can set an input channel for when the IMP-S is powered on.

[Table 8.19] Start-up channel

Setting value	Start-up power state of input channel
IN1 to IN4	Input channel that is set
OFF	OFF
LAST CHANNEL	Last channel

8.10.2 Button security lockout at startup

Menu	POWER ON SETTING → BUTTON LOCK
Setting value	AUTO: The same setting as it was before powering on the IMP-S. [Default] UNLOCK LOCK

You can set a keylock state of input selection buttons for when the IMP-S is powered on.

[Table 8.20] Button security lockout at startup

Condition		Result
Setting value	The keylock state before the IMP-S is powered off or standby.	The keylock state after the IMP-S is powered on.
AUTO	UNLOCK	UNLOCK
	LOCK	LOCK
UNLOCK	UNLOCK	UNLOCK
	LOCK	
LOCK	UNLOCK	LOCK
	LOCK	

8.11 Advanced settings

Buzzer and version display functions are explained in this section. See “7.2 WEB menu operation” for other settings.

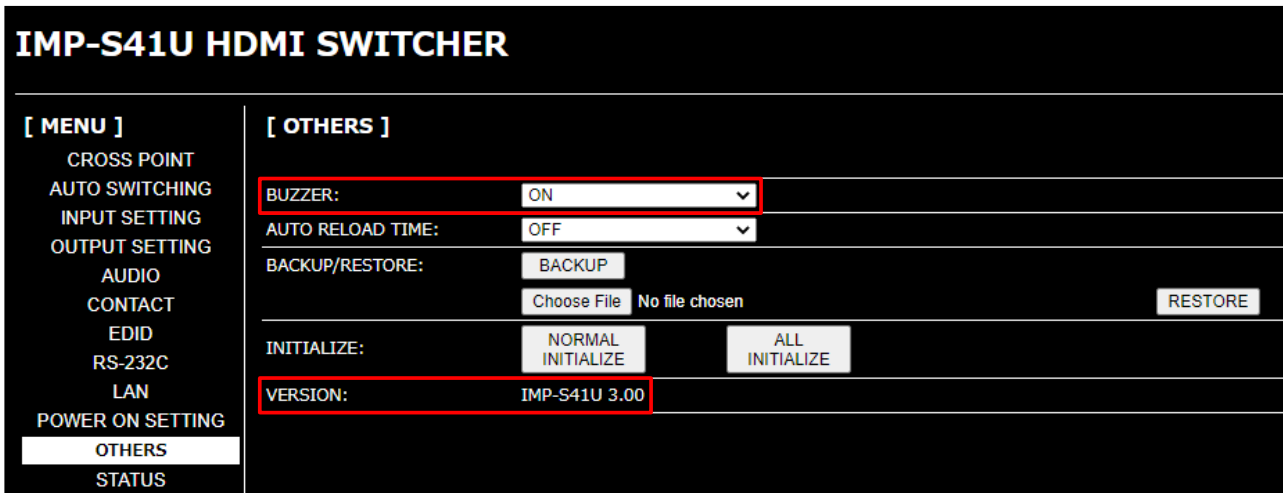

[Fig. 8.21] Others (IMP-S41U)

[Table 8.21] Submenu and feature

Submenu	Feature	Page
BUZZER	Beep	72
AUTO RELOAD TIME	Setting automatic reload time of WEB menu	34
BACKUP/RESTORE	Saving/Restoring settings	35
INITIALIZE	Initialization	36
VERSION	Device information	72

8.11.1 Beep

Menu OTHERS → BUZZER

Setting value ON [Default]
OFF

You can enable/disable the buzzer tone for when input selection button is pressed.

8.11.2 Device information

Menu OTHERS → VERSION

You can view the firmware version.

8.12 Status

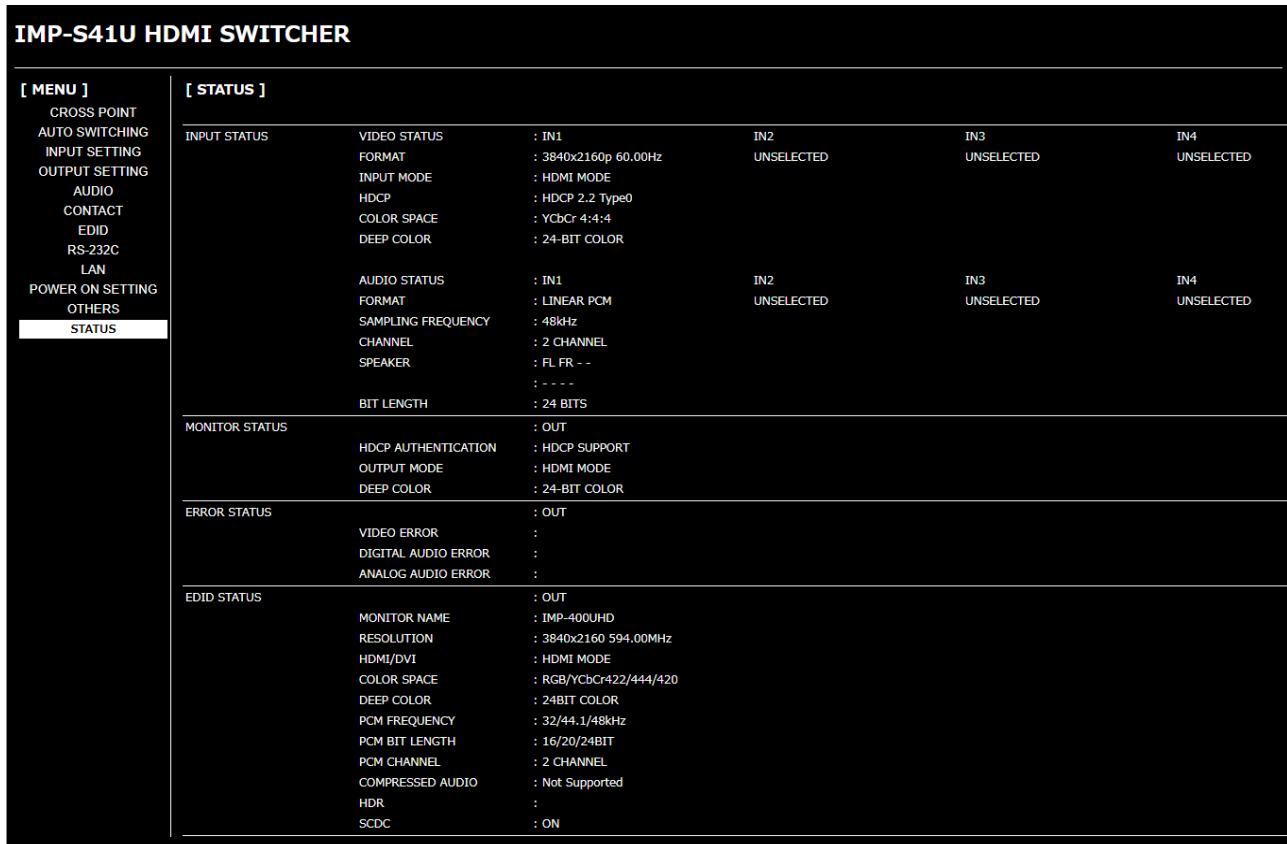

[Fig. 8.22] Status menu (IMP-S41U)

[Table 8.22] Submenu and feature

Submenu	Feature	Page
INPUT STATUS	Input signal status	74
MONITOR STATUS	Sink device status	77
ERROR STATUS	Displaying error message	78
EDID STATUS	Viewing sink device EDID	80

8.12.1 Input signal status

INPUT STATUS	VIDEO STATUS	: IN1	IN2
	FORMAT	: 3840x2160p 60.00Hz	UNSELECTED
	INPUT MODE	: HDMI MODE	
	HDCP	: HDCP 2.2 Type0	
	COLOR SPACE	: YCbCr 4:4:4	
	DEEP COLOR	: 24-BIT COLOR	
	AUDIO STATUS	: IN1	IN2
	FORMAT	: LINEAR PCM	UNSELECTED
	SAMPLING FREQUENCY	: 48kHz	
	CHANNEL	: 2 CHANNEL	
	SPEAKER	: FL FR - -	
		: - - - -	
	BIT LENGTH	: 24 BITS	

[Fig. 8.23] Input signal status (Example: IN1 and IN2)

Menu **STATUS** → INPUT STATUS

Values to be acquired

You can display the input signal status that is input from an HDMI input connector.

[Table 8.23] Input video signal format

Item	Example	Description
FORMAT	3840x2160p 59.94Hz	SDTV/HDTV/UHDTV signal is input. Format type and vertical synchronous frequency is displayed.
	800x600p 60.32Hz	VESA signal is input. Horizontal resolution × Vertical resolution and vertical synchronous frequency are displayed.
	NO SIGNAL	No video signal is input.
	UNSELECTED	No input channel is selected.

[Table 8.24] Input signal type

Item	Example	Description
INPUT MODE	HDMI MODE	HDMI signal is input.
	DVI MODE	DVI signal is input.

[Table 8.25] HDCP input

Item	Example	Description
HDCP	HDCP 2.2 Type0	HDCP 2.2 stream type 0 signal is input.
	HDCP 2.2 Type1	HDCP 2.2 stream type 1 signal is input.
	HDCP 1.4	HDCP 1.4 signal is input.
	NOT ENCRYPTED	Signal that is not protected by HDCP is input.

[Table 8.26] Color space of video input signal

Item	Example	Description
COLOR SPACE	RGB	RGB signal is input.
	YCbCr 4:2:2	YCbCr 4:2:2 signal is input.
	YCbCr 4:4:4	YCbCr 4:4:4 signal is input.
	YCbCr 4:2:0	YCbCr 4:2:0 signal is input.

[Table 8.27] Color depth of video input signal

Item	Example	Description
DEEP COLOR	24-BIT COLOR	24 bit/pixel (8 bit/component) signal is input.
	30-BIT COLOR	30 bit/pixel (10 bit/component) signal is input.
	36-BIT COLOR	36 bit/pixel (12 bit/component) signal is input.

[Table 8.28] Audio input signal format

Item	Example	Description
FORMAT	LINEAR PCM	LPCM signal is input.
	COMPRESSED AUDIO	Compressed signal (such as Dolby Digital, DTS) is input. (The IMP-S does not determine detailed formats. "COMPRESSED AUDIO" is displayed for all compressed audio.)
	NO SIGNAL	No audio signal is input.

[Table 8.29] Sampling frequency of audio input signal

Item	Example	Description
SAMPLING FREQUENCY	48kHz	Sampling frequency (32/44.1/48/88.2/96/176.4/192kHz) is displayed.

[Table 8.30] The number of audio input channels

Item	Example	Description
CHANNEL	2 CHANNEL	2-channel audio is input.
	MULTI CHANNEL	Multi-channel audio is input.

[Table 8.31] Speaker configuration of audio input signal

Item	Example	Description
SPEAKER	FL FR	Speaker configuration (FL/FR/LFE/FC/RL/RR/RC/FLC/FRC/RLC/RRC/LW/FRW/FLH/FRH/TC/FCH) is displayed.

[Table 8.32] Bit length of audio input signal

Item	Example	Description
BIT LENGTH	24 BITS	Bit length (16/20/24 BITS) is displayed.

8.12.2 Sink device status

MONITOR STATUS	: OUT
HDCP AUTHENTICATION	: HDCP SUPPORT
OUTPUT MODE	: HDMI MODE
DEEP COLOR	: 24-BIT COLOR

[Fig. 8.24] Sink device status

Menu **STATUS** → MONITOR STATUS

Values to be acquired

You can display information of the sink device that is connected to an HDMI output connector.

[Table 8.33] HDCP authentication status

Item	Example	Description
HDCP AUTHENTICATION	HDCP SUPPORT	HDCP-compliant sink device is connected.
	HDCP NOT SUPPORT	Non-HDCP-compliant sink device is connected or input signal is without HDCP.
	HDCP ERROR	HDCP-compliant sink device is connected, but the authentication failed.
	HDCP CHECK NOW	Sink device status is being checked.
	UNCONNECTED	No sink device is connected.

[Table 8.34] Output signal type

Item	Example	Description
OUTPUT MODE	HDMI MODE	HDMI signal is output.
	DVI MODE	DVI signal is output.

[Table 8.35] Color depth of video output signal

Item	Example	Description
DEEP COLOR	24-BIT COLOR	24 bit/pixel (8 bit/component) signal is output.
	30-BIT COLOR	30 bit/pixel (10 bit/component) signal is output.
	36-BIT COLOR	36 bit/pixel (12 bit/component) signal is output.

8.12.3 Displaying error message

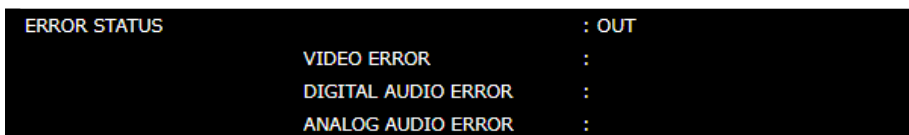

[Fig. 8.25] Error message

Menu STATUS → ERROR STATUS

Values to be acquired

[Table 8.36] Error message

Item	Example	Description
VIDEO ERROR	Not DDC Power	No DDC power is input. (No source device is connected.)
	No Signal	No video signal is input.
	AV Mute Received	Video output of source device is muted.
	HDCP Video Mute	Signal with HDCP is input, but the sink device does not support HDCP.
	Not AVInfoFrame	The source device does not output packet that is necessary for video output.
	Dot Clock Over	The IMP-S does not support the input signal.
	Channel OFF	Input channel is set to "OFF".

[Table 8.37] Digital audio error message

Item	Example	Description
DIGITAL AUDIO ERROR	Audio Mute	“ 8.5.1 Output mute ” is set to “Mute ON”.
	Not DDC Power	No DDC power is input. (No source device is connected.)
	No Signal	No audio signal is input.
	AV Mute Received	Audio output of source device is muted.
	HDCP Audio Mute	Signal with HDCP is input, but the sink device does not support HDCP.
	Not AUDInfoFrame	The source device does not output packet that is necessary for audio output.
	Compressed Audio	Audio cannot be output because compressed audio is input. (Compressed audio is output to only sink device supporting compressed audio)
	DVI Mode	DVI signal is input from a source device, “ 8.4.1 Output mode ” is set to DVI output, or a sink device that does not support digital audio is connected.
	Channel OFF	Input channel is set to “OFF”.

[Table 8.38] Analog audio error message

Item	Example	Description
ANALOG AUDIO ERROR	Audio Mute	“ 8.5.1 Output mute ” is set to “Mute ON”.
	Not DDC Power	No DDC power is input. (No source device is connected.)
	No Signal	No audio signal is input.
	AV Mute Received	Audio output of source device is muted.
	Not AUDInfoFrame	The source device does not output packet that is necessary for audio output.
	Compressed Audio	Audio cannot be output because compressed audio is input. (If compressed audio is input, analog audio is not output.)
	DVI Mode	DVI signal is input from source device.
	Channel OFF	Input channel is set to “OFF”.

8.12.4 Viewing sink device EDID

```

EDID STATUS                                     : OUT
MONITOR NAME                                   : IMP-400UHD
RESOLUTION                                     : 3840x2160 594.00MHz
HDMI/DVI                                       : HDMI MODE
COLOR SPACE                                    : RGB/YCbCr422/444/420
DEEP COLOR                                     : 24BIT COLOR
PCM FREQUENCY                                  : 32/44.1/48kHz
PCM BIT LENGTH                                 : 16/20/24BIT
PCM CHANNEL                                    : 2 CHANNEL
COMPRESSED AUDIO                              : Not Supported
HDR                                             :
SCDC                                           : ON

```

[Fig. 8.26] Viewing sink device EDID

Menu **STATUS** → EDID STATUS

Values to be acquired

You can display EDID of the sink device that is connected to an HDMI output connector.

[Table 8.39] Monitor's EDID

Item	Displayed value	Example	Remarks
MONITOR NAME	—	IMP-S41U	If no monitor is connected, "UNCONNECTED" is displayed. Then, no EDID information will be displayed.
RESOLUTION	—	1920x1080 148.50MHz	—
HDMI/DVI	HDMI MODE/ DVI MODE	HDMI MODE	If the sink device does not support HDMI, "DVI MODE" is displayed.
COLOR SPACE ^{*1}	RGB/YCbCr422/ YCbCr444/YCbCr420	RGB/YCbCr422/444	All supported sampling structures are displayed. If the sink device's resolution is 4K@50/59.94/60 and if it supports up to YCbCr 4:2:0, "YCbCr420" is displayed.
DEEP COLOR ^{*1}	24/30/36 BIT COLOR	24BIT COLOR	All supported color depth are displayed.
PCM FREQUENCY ^{*2}	32/44.1/48/88.2/96/ 176.4/192 kHz	32/44.1/48kHz	All supported sampling frequencies are displayed.
PCM BIT LENGTH ^{*2}	16/20/24 BIT	16/20/24BIT	All supported bit length are displayed.

[Table 8.40] Monitor's EDID (Cont'd)

Displayed value	Displayed value	Example	Remarks
PCM CHANNEL ^{*2}	1 CHANNEL to 8 CHANNEL	2 CHANNEL	—
COMPRESSD AUDIO ^{*2}	Supported/ Not Supported	Supported	If compressed audio is supported, "Supported" is displayed.
HDR ^{*3}	ON	ON	If HDR is supported, "ON" is displayed.
SCDC ^{*3}	ON	ON	If SCDC is supported, "ON" is displayed.

^{*1} Displayed only if a sink device that supports HDMI is connected.

^{*2} Displayed only if a sink device that supports audio is connected.

^{*3} Displayed only if a sink device that supports HDR or SCDC is connected.

9 Product Specification

		IMP-S21U	IMP-S41U
Video/Audio input	HDMI	2 inputs HDMI/DVI 1.0 TMDS single link, HDCP 1.4/2.2 TMDS clock: Up to 300 MHz, TMDS data rate: Up to 18 Gbps Deep color/x.v.Color/3D/HDR/HEC ¹ 640x480@60 to 2560x1600@60 Reduced Blanking 480i, 576i to 3840x2160@24/25/30/50/59.94/60 (4:4:4), 3840x2160@50/59.94/60 (4:2:0), 4096x2160@24/25/30/50/59.94/60 (4:4:4), 4096x2160@50/59.94/60 (4:2:0) Color depth: 24/30/36 bits *For all supported video signals, see the table below. LPCM: Up to 8 channels Sampling frequency: 32/44.1/48/88.2/96/176.4/192 kHz Reference level: -20 dBFS, Max. input level: 0 dBFS CEC Connector: HDMI Type A (19-pin) Maximum distances: 98 ft. (30 m) (1080p@60), 39 ft. (12 m) (4K@60) ²	4 inputs
	HDMI	1 output HDMI/DVI 1.0 TMDS single link, HDCP 1.4/2.2 TMDS clock: Up to 300 MHz, TMDS data rate: Up to 18 Gbps Deep color/x.v.Color/3D/HDR/HEC ¹ 640x480@60 to 2560x1600@60 Reduced Blanking 480i, 576i to 3840x2160@24/25/30/50/59.94/60 (4:4:4), 3840x2160@50/59.94/60 (4:2:0), 4096x2160@24/25/30/50/59.94/60 (4:4:4), 4096x2160@50/59.94/60 (4:2:0) Color depth: 24/30/36 bits *For all supported video signals, see the table below. LPCM: Up to 8 channels Sampling frequency: 32/44.1/48/88.2/96/176.4/192 kHz Reference level: -20 dBFS, Max. output level: 0 dBFS CEC Connector: HDMI Type A (19-pin) Maximum distances: 98 ft. (30 m) (1080p@60), 39 ft. (12 m) (4K@60) ²	
Video/Audio output	Analog audio	1 output Stereo LR Output impedance: 100 Ω balanced/50 Ω unbalanced Reference level: -4 dBu balanced/-10 dBu unbalanced Max. output level: +16 dBu balanced/+10 dBu unbalanced Connector: Captive screw (5-pin)	
	RS-232C	1 port/Connector: Captive screw (3-pin)	
Control I/F	LAN	1 port/10Base-T/100Base-TX (Auto Negotiation), Auto MDI/MDI-X, Connector: RJ-45	
	Contact input/ Tally output	3 ports Contact input: Non-voltage contact (make contact) input or voltage contact output (DC 0 V to 5 V ±5%) Tally output: Open collector output (Rated DC 48 V 1 A) Connector: Captive screw (3-pin) LED power for Tally (Rated DC 5 V 0.5 A) connector: Captive screw (3-pin)	5 ports
Functions	Audio	De-embedding	
	Control	WEB browser, CEC through (Connector: HDMI)	
	Others	Automatic input switching, Input channel sequence switching, Last memory, Anti-Snow, Connection Reset ³ , Button security lockout	
General	Power	DC 5 V 0.9 A	DC 5 V 1.1 A
	Power consumption	6 W	7 W
	Dimensions	8.3 (W) × 1.7 (H) × 5.5 (D)" (210 (W) × 42 (H) × 140 (D) mm) (Excluding connectors and the like)	
	Weight	2.4 lbs. (1.1 kg)	
	Temperature	Operating: 32°F to 104°F (0°C to +40°C), Storage: -4°F to +176°F (-20°C to +80°C)	
	Humidity	20% to 90% (Non Condensing)	

¹ ARC/HEC are not supported.

² The maximum specified distances may not be achievable with some device combinations, cabling method, or other manufacturer's cable. For the same reasons, video signal disturbances or interruptions may occur, even if signals are within the specified distance (cable length) parameters. The maximum cable length varies depending on the connected devices. The specifications have been qualified under following conditions:

- HDMI (1080p@60) : When IDK's 24 AWG cable was used and signals of 1080p@60 24 bits was transmitted.
- HDMI (4K@60) : When IDK's 18 Gbps supported cable was used and signals of 3840x2160@60 24 bits was transmitted.

³ For digital systems, some problems, such as an HDCP authentication error, can often be recovered by physically disconnecting and reconnecting the digital cables. However, the Connection Reset feature will correct these problems automatically without the need to physically plug and unplug the cables. It creates the same condition as if the cable were physically disconnected and reconnected. This feature only works for the IMP-S's output. Connecting other devices between the IMP-S's outputs and sink devices, may interfere with the operation of this feature.

9.1 Supported video signals

Signal	Resolution	Frame Rate [Hz]	Pixel Clock [MHz]	Color Depth [bits]	INPUT	OUTPUT
					HDMI	HDMI
640x480@60	640x480	59.94	25.18	24/30/36	○	○
800x600@60	800x600	60.32	40.00	24/30/36	○	○
1024x768@60	1024x768	60.00	65.00	24/30/36	○	○
1280x768@60	1280x768	59.87	79.50	24/30/36	○	○
1280x800@60	1280x800	59.81	83.50	24/30/36	○	○
1280x960@60	1280x960	60.00	108.00	24/30/36	○	○
1280x1024@60	1280x1024	60.02	108.00	24/30/36	○	○
1360x768@60	1360x768	60.02	85.50	24/30/36	○	○
1366x768@60	1366x768	59.79	85.50	24/30/36	○	○
1400x1050@60	1400x1050	59.98	121.75	24/30/36	○	○
1440x900@60	1440x900	59.89	106.50	24/30/36	○	○
1600x900@60	1600x900	59.95	118.25	24/30/36	○	○
1600x1200@60	1600x1200	60.00	162.00	24/30/36	○	○
1680x1050@60	1680x1050	59.95	146.25	24/30/36	○	○
1920x1080@60 RB	1920x1080	59.93	138.50	24/30/36	○	○
1920x1200@60 RB	1920x1200	59.95	154.00	24/30/36	○	○
2048x1152@60 RB	2048x1152	60.00	162.00	24/30/36	○	○
2560x1440@60 RB	2560x1440	59.95	241.50	24/30/36	○	○
2560x1600@60 RB	2560x1600	59.97	268.50	24/30/36	○	○
480i	720x480	59.94	27.00	24/30/36	○	○
480p	720x480	59.94	27.00	24/30/36	○	○
576i	720x576	50.00	27.00	24/30/36	○	○
576p	720x576	50.00	27.00	24/30/36	○	○
720p@50	1280x720	50.00	74.25	24/30/36	○	○
720p@59.94	1280x720	59.94	74.18	24/30/36	○	○
720p@60	1280x720	60.00	74.25	24/30/36	○	○
1080i@50	1920x1080	25.00	74.25	24/30/36	○	○
1080i@59.94	1920x1080	29.97	74.18	24/30/36	○	○
1080i@60	1920x1080	30.00	74.25	24/30/36	○	○
1080p@50	1920x1080	50.00	148.50	24/30/36	○	○
1080p@59.94	1920x1080	59.94	148.35	24/30/36	○	○
1080p@60	1920x1080	60.00	148.50	24/30/36	○	○
3840x2160@23.98	3840x2160	23.98	296.70	24/30/36	○	○
3840x2160@24	3840x2160	24.00	297.00	24/30/36	○	○
3840x2160@25	3840x2160	25.00	297.00	24/30/36	○	○
3840x2160@29.97	3840x2160	29.97	296.70	24/30/36	○	○
3840x2160@30	3840x2160	30.00	297.00	24/30/36	○	○
3840x2160@50	3840x2160	50.00	594.00	24/30/36*	○	○
3840x2160@59.94	3840x2160	59.94	593.40	24/30/36*	○	○
3840x2160@60	3840x2160	60.00	594.00	24/30/36*	○	○
4096x2160@23.98	4096x2160	23.98	296.70	24/30/36	○	○
4096x2160@24	4096x2160	24.00	297.00	24/30/36	○	○
4096x2160@25	4096x2160	25.00	297.00	24/30/36	○	○
4096x2160@29.97	4096x2160	29.97	296.70	24/30/36	○	○
4096x2160@30	4096x2160	30.00	297.00	24/30/36	○	○
4096x2160@50	4096x2160	50.00	594.00	24/30/36*	○	○
4096x2160@59.94	4096x2160	59.94	593.41	24/30/36*	○	○
4096x2160@60	4096x2160	60.00	594.00	24/30/36*	○	○

RB: Reduced Blanking

*For RGB/YCbCr 4:4:4, only 24 bit is supported.

For best results, please confirm that the source device(s) video output can be configured to match the listed formats above. For questions regarding other input video signals, please contact your IDK representative.

10 Troubleshooting

This chapter provides recommendations in case difficulties are encountered during IMP-S setup and operation.

In case the IMP-S does not work correctly, please check the following items first.

- Are the IMP-S and all devices connected to power and powered on?
- Are signal cables connected correctly?
- Are there any loose or partially mated connections?
- Are the interconnecting cables specified correctly to support adequate bandwidth?
- Are specifications of connected devices matched to each other?
- Are configuration settings for the connected devices correct?
- Is there any nearby equipment that may cause electrical noise/RF interference?

If the problem persists, review the following section for guidelines and recommendations. Refer to the manuals of connected devices as well, since they may possibly be the cause of the problem.

Problem	Cause/Check item/Solution	Page
• Video output		
Video is not being output.	<p>Check the error message in “8.12.3 Displaying error message”.</p> <ul style="list-style-type: none"> • Error message is “Not DDC Power”: Check if the source device is connected and powered on. • Error message is “No Signal”: No signal is input. Check [1] to [5] on the next page. • Error message is “AV Mute Received”: An error may be occurring in the source device or specifically with HDCP authentication. Check [2], [4], and [5]. • Error message is “HDCP Video Mute”: If the display device or other connected AV signal component does not support HDCP, only content without content protection (such as from an analog input and test pattern) will be served. When content with protection is input, a black screen is output. Some HDMI/DVI devices query the connected device to determine HDCP compliance and whether or not to output an HDCP encrypted signal. Since the IMP-S is HDCP compliant, video may not be output if the IMP-S is connected to a sink device or AV amplifier that does not support HDCP. In this case and if the content is not protected, disable HDCP for that input port on the IMP-S. See “8.3.2 HDCP input” for details. • Error message is “Not AVInfoFrame”, or “Dot Clock Over”: An error is occurring within the source device. • Error message is “Channel OFF”: Set “7.1.1 Selecting input channels” to a value other than “OFF”. 	—

Problem	Cause/Check item/Solution	Page
Video is not being output.	[1] The time setting for monitoring no-signal input may be too short.	52
	[2] Check if the selected input resolution is supported by the sink device. <ul style="list-style-type: none"> • If you select 1080i, video may not be output to sink devices that do not support interlaced signal. • Some monitors for PC do not support TV resolutions. • Some LC TVs do not support PC resolutions (VGA to WQXGA). 	59
	[3] Check the video output setting of the source device.	—
Video has disappeared, is intermittent, or presents noise.	[4] If using a long cable for input or output, replace it with a 16 ft. (5 m) or shorter cable. Since the IMP-S has automatic cable length equalization, long cables can be successfully used, but the IMP-S's full performance may not be realized if the cable or connected peripheral devices are of inferior quality. If the error is solved by replacing the cable, the signal may have been degraded due to excessive attenuation or crosstalk. IDK offers high-quality cables, cable boosters and extenders. Please contact us as needed.	—
	[5] When high-speed signals (high resolution: such as UXGA, WUXGA, QWXGA, WQHD, WQXGA, 1080p, 4K; DEEP COLOR signal) are presented to the input or provided by the output, video may not be displayed or noise may appear. This is largely dependent on cable quality and the characteristics of connected peripheral devices. This is largely dependent on cable quality and the characteristics of connected peripheral devices. If the problem occurs only when a specific input is selected, the problem is being caused by difficulties ahead of that input port. If it occurs for all inputs or when an internal IMP-S test pattern is displayed, the problem is related to the output side of the system. One possible solution is to change to a lower resolution format and/or disable Deep color. You can check the resolution and color depth of the input signal in "8.12.1 Input signal status" and you can also limit resolution and color depth of input signal as defined by the IMP-S's EDID configuration settings. You can specify the output resolution and check the color depth of the output signal in "8.12.2 Sink device status" .	59, 63
The left, right, top and bottom sides are cut off.	Since some sink devices display video in overscan mode, video may be cut off. Check the display setting of the sink device.	—
Black is displayed at top, bottom, right and left on PC video or only part of the PC video is displayed, and the rest can be revealed by scrolling with the mouse.	Does the PC resolution (you can check it in "Properties" of the PC) match the resolution that is output from the PC (you can check it in "8.12.1 Input signal status"). If not, set the EDID and PC resolutions. For laptops, if the "copydesktop" is enabled, the output to an external monitor is limited to the resolution of the laptop's native LCD screen. As a result, black may be displayed at edges. The problem can be solved by enlarging the display, extending the desktop or displaying only to the external monitor.	59

Problem	Cause/Check item/Solution	Page
Video is reduced vertically or horizontally.	Some sink devices display input video on the full screen regardless of aspect ratio. Check the display setting of the sink device. Since some resolutions are always displayed on the full screen, change the output resolution of the source device.	—
Video flickers	If an interlace signal is input to a sink device that does not support interlace inputs, the video may flicker. Check the output resolution of the sink device.	74
PC's dual monitor cannot be set or the setting is canceled.	If the monitoring function for no-signal input is enabled, the dual monitor function of your PC may not work correctly. In this case, disable the monitoring function.	52
It takes a long time to output video after video input is switched.	If a channel signal without HDCP support is input and then is switched to a channel signal with HDCP support is input, some sink devices fail HDCP authentication. In this case, it may temporarily not output video and audio.	—
● Audio output		
Audio is not being output.	<p>If audio is not being output, first check the error code in “8.12.3 Displaying error message”.</p> <ul style="list-style-type: none"> • Error message is “Audio Mute”: Set “8.5.1 Output mute” to “OFF”. • Error message is “Not DDC Power”: Ensure that the source device is connected and powered on. • Error message is “No Signal”: Signal is not input. Check [6], [7], and [9]. • Error message is “AV Mute Received”: There may be problems in the source device side or HDCP authentication. [6]. • Error message is “HDCP Audio Mute”: If the display device or AV amplifier does not support HDCP, only signals without content protection will be output; audio is not output when signal with content protection is applied to input. Some HDMI/DVI source devices check if the connected device is HDCP compliant and determines whether to output an HDCP encrypted signal or not. Since the IMP-S is HDCP compliant, audio may not be output if the IMP-S is connected to a sink device or AV amplifier that does not support HDCP. In this case, disable HDCP input for the port supporting the source device. “8.3.2 HDCP input”. • Error message is “Not AUDInfoFrame”: There are problems in the source device. • Error message is “Compressed Audio”: LCD monitors may not output compressed audio, such as Dolby Digital, DTS, and so on. If playing content with compressed audio (such as Blu-ray disc), check the audio output setting. The audio signal parameters terminating from the source device can be controlled by changing the EDID settings for input port(s). 	64

Problem	Cause/Check item/Solution	Page
● Audio output (Cont'd)		
Audio is not being output.	<ul style="list-style-type: none"> ▪ Error message is “DVI Mode”: Set “8.4.1 Output mode” to a mode other than “DVI output”. If the sink device does not support HDMI signals, the IMP-S outputs DVI automatically. Check which signal type is supported by the sink device. ▪ Error message is “Channel OFF”: Set “7.1.1 Selecting input channels” to “OFF”. ▪ If no error message is displayed: Check [6] to [9]. The source device may not be outputting audio. 	—
	[6] Is video being output correctly? If not, check [1] to [5].	—
	[7] Is DVI signal output from the source device? You can check the input signal type in “ 8.12.1 Input signal status ”. DVI signal may be output automatically depending on EDID settings. If a source device that does not support 4K is connected to the input connector to which 4K EDID is set, DVI signal may be output. Change the setting of “ 8.7.1 EDID resolution ” to a value other than 4K.	59
	[8] Is the input audio format supported by the connected sink device or AV amplifier input? Typically, LCD monitors may not output 88.2 kHz or higher sampling frequency of LPCM and compressed audio (such as Dolby Digital, DTS, and other format). The source device’s audio signal characteristics can be managed by the IMP-S’s EDID configuration settings.	64
	[9] Check the audio output setting of the source device.	—
Audio is output from HDMI output connectors, but audio is not output from analog output connector.	If compressed audio (such as Dolby Digital, DTS, and other formats) is applied to the input, analog audio is not provided at output. The analog audio output supports only 2 channel LPCM. You can check the input audio type in “ 8.12.1 Input signal status ”.	64
Audio is output from analog output connector, but audio is not output from HDMI output connectors.	Does the connected sink device support the input resolution? If a PC resolution (VGA to 4K) is input, sink device may not output audio.	59
	Does the connected sink device support the sampling frequency? Some LC monitors do not support high sampling frequencies (88.2 kHz or higher). Audio signal that is output from the source device can be controlled by EDID setting.	64

Problem	Cause/Check item/Solution	Page
● Audio output (Cont'd)		
Compressed audio (such as Dolby Digital, DTS) is not output from the source device.	Compressed audio input is set to OFF (EDID settings) by factory default. If using compressed audio, change the EDID setting.	64
	In order to output multi-channel compressed audio, configure the IMP-S's EDID profile to define the correct number of speakers.	65
	Check the audio output settings of the source device.	—
Multi-channel audio is not output.	In order to output multi-channel audio, configure the IMP-S's EDID profile to define the correct number of speakers.	65
● Button operation		
Buttons do not operate.	Ensure that buttons are not locked.	26, 32
	Immediately after start-up, all buttons are disabled until the connection of the sink device is confirmed.	24
● Communication command control		
Control commands cannot be issued from PC to the IMP-S.	Are the following items set correctly?	
	For RS-232C: Baud rate and data word length	66
	For LAN : IP address and subnet mask	68
	Immediately following start-up, the remote command feature is disabled until connection with sink device is confirmed.	24
● Others		
Devices cannot be controlled through CEC.	Are HDMI cables that support CEC being used?	—
	In order to use CEC, use an HDMI cable that supports CEC. To use CEC, enable the HDMI link control of the connected devices (such as LCD TVs, Blu-ray recorder, and other formats).	

If additional assistance is required, please perform the following tests and then contact us.

No.	Checking items	Result
1	The problem occurs at all connectors?	Yes or No
2	Connect the devices using genuine cables without connecting the IMP-S. The problem still cannot be solved? Please contact us for assistance.	Yes or No

User Guide of IMP-S Series

Ver.2.1.0

Issued on: 18 March 2022



Headquarters

IDK Corporation
7-9-1 Chuo, Yamato-shi, Kanagawa-pref.
242-0021 JAPAN
TEL: +81-46-200-0764 FAX: +81-46-200-0765

Email: idk_eng@idk.co.jp

URL: www.idkav.com

USA

IDK America Inc.
72 Grays Bridge Road Suite 1-C, Brookfield, CT 06804
TEL: +1-203-204-2445

Email: sales@idkav.com

URL: www.idkav.com

Europe

IDK Europe GmbH
Lise-Meitner-Str. 6, D-40878 Ratingen
TEL: +49-2102-578-301-0

Email: info@idkav.eu

URL: www.idkav.com



Product information Support

Arvanics Corporation
7-9-1 Chuo, Yamato-shi, Kanagawa-pref.
242-0021 JAPAN
TEL: +81-46-259-6920 FAX: +81-46-259-6930

Email: info@arvanics.com

URL: www.arvanics.com

Information in this document is subject to change without notice.

©2021 IDK Corporation, all rights reserved. All trademarks mentioned are the property of their respective owners.